

Automated Canning System V4.2 Manual

ACS V4.2

CASK BREWING SYSTEM INC.

Third Edition, November 2016



cask
global canning solutions



Toll Free: 1-800-661-8443 Direct: +1 403-640-4677 Fax: +1 403-640-4680 e-mail: info@cask.com

Technical Service & Support

1-800-661-8443 Option #4
support@cask.com

Parts Order

1-800-661-8443 Option #4
parts@cask.com

cask.com



Official supplier of Ball Corporation for the supply of printed aluminum cans to our customers



Confidential

Automated Canning System (ACS) V4.2 Manual

Third Edition, September 2016

Copyright

© 2016 Cask Brewing Systems Inc. All rights reserved.

Disclaimer

The information presented in this manual has been reviewed and validated for accuracy. The included set of instructions and descriptions are accurate for the Cask Brewing Systems Inc. Automated Canning System Version 4.2 (ACS V4.2) in its stock condition as supplied by Cask Brewing Systems Inc., at the time of this manual's production. However, subsequent products and manuals are subject to change without notice. Therefore, Cask Brewing Systems Inc. assumes no liability for damages incurred directly or indirectly from errors, omissions, or discrepancies between any subsequent or altered products and this manual.





Revision History & Document Control

Manual Version	Release Date	System	Updates
First Edition	August 2011	ACS V4.0	<ul style="list-style-type: none">• Initial Manual Release.
Second Edition	February 2014	ACS V4.1	<ul style="list-style-type: none">• Updated electrical section for new V4.1 panel design.• Expanded Frequently Asked Questions section.
Third Edition	November 2016	ACS V4.2	<ul style="list-style-type: none">• Formatting update.• Can Seam Evaluation videos added.• Updated Parts List.• Expanded “Can Table Height Adjustment” section

Future Updates

As we evolve future iterations of this Manual, we will post the most recent versions and updates on-line at our website.

www.cask.com/customer-login/

Password: CaskCustomer

Note: you will also require the below username to download the PDF version of the manuals.

Username: CaskCanning123



Table of Contents

- Section A. Before You Begin 4
 - A.1 Unit Diagram 4
 - A.2 System Requirements 4
- Section B. Unit Setup 5
 - B.1 Uncrating Requirements 5
 - B.2 Uncrating Procedure 5
 - B.3 Packing List / Loose Parts 6
 - B.4 Initial Adjustments & Settings 6
 - B.5 Unloading Cans 7
- Section C. ACS Operations Overview 9
 - C.1 System Operation Walkthrough 9
 - C.2 Controllers 9
 - C.3 HMI Control Panel Operations 12
 - C.4 Electrical Panel Overview 13
 - C.5 Can Filling 18
 - C.6 Lid Dispenser 19
 - C.7 Parts in Motion: Pneumatics 19
 - C.8 Parts in Motion: Motors 20
- Section D. ACS System Operations 22
 - D.1 Initial Start-up Adjustments & Settings 22
 - D.2 Pre-Start Checklist 22
 - D.3 Startup & Operation 23
 - D.4 Clean in Place (CIP) System 23
 - D.5 ACS Post-Operation Shutdown Checklist 24
 - D.6 System Periodic Maintenance 25
 - D.7 Parts List 25
 - D.8 Adjustment & Troubleshooting 27
 - D.9 Frequently Asked Questions 32
- Section E. Seam Measurement 37
 - E.1 Can Seam Evaluation Training Videos 37
 - E.2 Manual Seam Evaluation Process 38
 - E.3 Reading a Seam Micrometer 38
 - E.4 Seam Measurement 39
 - E.5 Seam Troubleshooting 42
 - E.6 Seam Specifications 42
- Section F. Can Seamer 43
 - F.1 Seamer Adjustment & Troubleshooting 43
 - F.2 Seamer Troubleshooting 47
 - F.3 Bearing Replacement 47
- Section G. Safety 49
- Section H. Warranty Information 50
- Section I. Company Information 51



Section A. Before You Begin

A.1 Unit Diagram

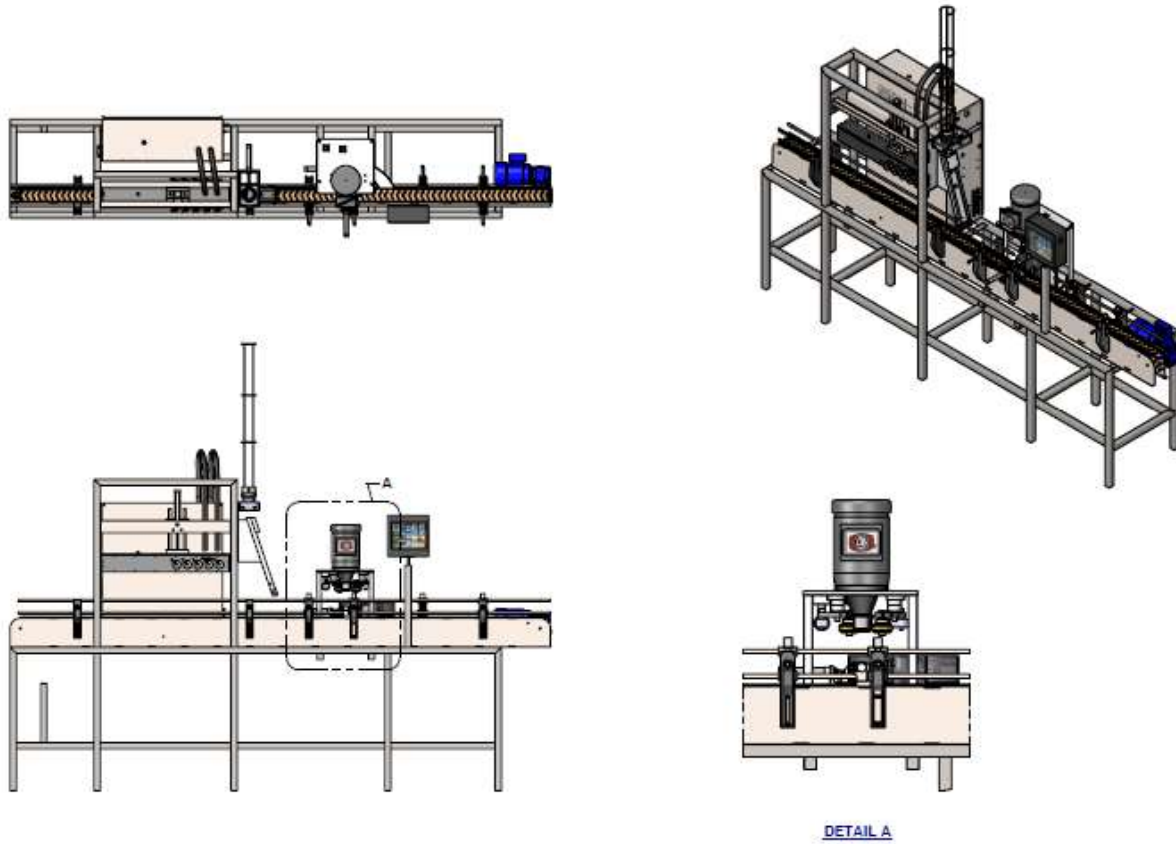

Figure 1 Automated Canning System - Unit Diagram

A.2 System Requirements

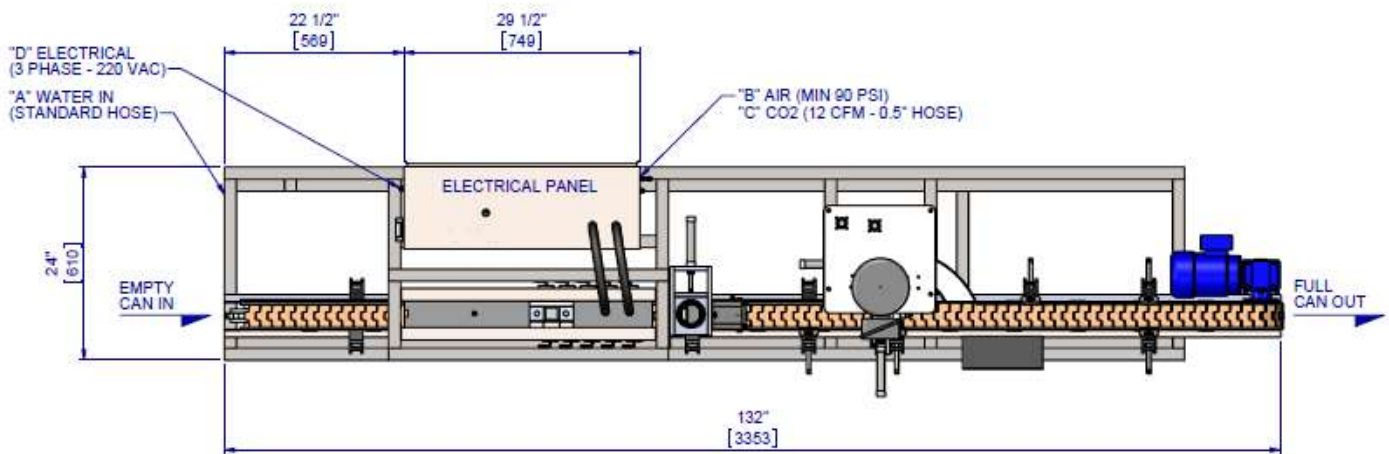

Figure 2 Top View - Canning System Requirements – all hookups except drain on backside of unit

Section B. Unit Setup

B.1 Uncrating Requirements

Recommended Tools

- Bolt cutters or large pair of wire cutters to remove metal bands
- Pry bar (recommend 2)
- Claw hammer
- Freestanding 10' Ladder
- Forklift
- Cordless drill with Robertson/Phillips bit

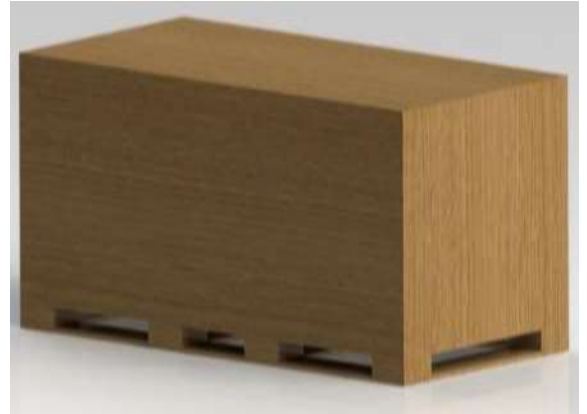

Figure 3 In case you've never seen a crate before

B.2 Uncrating Procedure

Refer to Figure 4 Uncrating your new Cask ACS.

- Inspect crate exterior and document any damage incurred in transit
- Cut metal bands and remove from exterior of crate
- Use pry bars to remove plywood covering each end (Figure 4 – Step 1)
- Next remove plywood skin from top of crate (Figure 4 – Step 2)
- Leave end supports and remove all top cross supports with hammer
- Brace sides or have someone hold them in place and remove last top cross supports
- Gently fold sides of crate down to the floor (Figure 4 – Step 3)
- You now have unfettered access to contents



1



2



3

Figure 4 Uncrating your new Cask ACS

B.3 Packing List / Loose Parts

Inside the container you'll find the following items packed along with the main machine

- Lid Cage
- Conveyer Catch Tray
- Tool kit
- Twist rinser (if ordered)
- Spare parts package (if ordered)
- Darex Manual "Evaluating and Controlling Double Seams Manual"

B.3.1 Moving Unit into Position

- After removing bands and holding blocks securing canning machine to pallet base, use forklift (lift truck) to move main unit into position (refer to unit footprint Figure 2 for clearances).
- Protect stainless finish by placing wood on lifting forks to prevent metal-on-metal contact.
- Spread forks so lifting points are as close to welded joints as possible to prevent bending cross supports.
- Slide lifting forks under lower supports centered on balance fulcrum of unit which is located on center of the machine.



Figure 5 Forklift moving Cask ACS into position

B.4 Initial Adjustments & Settings

Your Cask canning line has been factory tested prior to shipping to allow for trouble free installation by a Cask Technical Representative at your site.

Your warranty period will also commence at the date of installation and commissioning by a Cask Technical Rep.

Prior to arrival of your Cask Technical Rep, you should complete the following initial machine setup:

- Inspect overall machine shipping damage.
- Level machine in final production position.
- Have qualified electrician connect the machine to plant power (refer to C.4 Electrical Panel).
- Connect machine to compressed air supply (see Table 1).
- Connect machine to plant CO2 system (see Table 1).



- Connect machine to cold water supply (see Table 1)
 - Also recommended to have hot water access nearby machine for cleaning.

B.4.1 Machine Specification Sheet

Your Cask ACS will require the following utilities.

Power	208/230 volts, 50/60 Hz, 40 amps, 3 phase Electrical connection to be hardwired inside panel by certified electrician
Compressed Air	18 cfm at 125 psi Require a 7.0 peak HP, 50 gal/200L tank c/w refrigerated dryer and autofloat drain for Depal and ACS combined operation. Cask recommend compressor is CompAir L05 FS – 200 (23.66 CFM-0.67 m ³ /min).
Water Supply	½” cold water line – garden hose connection (testing) ½” hot water line – nearby machine (CIP)
CO ₂ Supply	20psi from plant system connected to machine with 3/8” barbed fitting
Drainage	Drainage is required from the canning table to drain (standard 1 ¼” waste pipe connection)
Beer	1.5 – 2” beer line from dispense tank. Beer supplied to machine at a temperature of 32 to 35.6 F (0 to 2 C).
Forklift	To unload the equipment on arrival

Table 1 ACS Machine Specifications

B.5 Unloading Cans

- The cans come stacked up to 8’9” high on Pallets (Figure 6 - A).
- The cans are very fragile and are subject to denting and damage in handling so be very careful.
- Verify straps are undamaged before moving full pallet.
- Resist impulse to touch stack or cans as damage will result.
- Each pallet footprint is 44” x 56”.
- A single truck load of cans contains up to 25 pallets of cans.
- Storage – Can be stacked 4 high, height permitting. One container load of cans on pallets require roughly 374 square feet of floor space.
- The lids for an entire container load of cans are on a single pallet (Figure 6 - B).

A



B



Figure 6 Forklift carrying your printed cans (A) and a pallet of can lids or ends (B)



Section C. ACS Operations Overview

C.1 System Operation Walkthrough

This section details the steps and procedures you'll need to familiarize yourself with in order to operate the ACS. This includes all functions and the effect of every switch and button on the machine. The following is a brief breakdown of the line's operation. Beginning at can in feed and following through to finished product out feed.

- The conveyer belt carries cans to the first gate. The gate, just after the fill head, has a dual function, A) stopping and holding cans under the fill head, and B) opening just long enough to allow the five filled cans to pass after fill cycle.
- The fill head waits for ten cans to accumulate underneath it before lowering. The first set of five cans are filled with beer. The second set of five cans are purged with CO₂. When the beer level reaches the sensors the fill stops, the head rises, and the gate opens to allow the 5 filled cans through and stops the 5 purged cans under the raised fill tubes.
- The filled cans leave the gate, pass under the lid dispenser where the leading edge of each can grabs a lid as it passes under the slide, pulling a lid onto the top of each can. The area immediately under the lid dispenser and the dome under the can lid are purged with CO₂ during the process.
- Cans then stop at the block before the #1 push cylinder. This block acts both to stop the flow, and trigger the cylinder to push the can onto the seamer lift table. This sensor also triggers the lid dispenser to drop another lid into the lid slide tray.
- Once on the lift table the can is raised into the chuck, which rotates the can. The #1 die pushes into chuck making the first seaming operation, followed by #2 which completes the seam, then the lift table lowers.
- The lowered can is pushed off the lift table by the oncoming can and deposited in front of the #2 push cylinder, which pushes it onto the out feed conveyer which carries it through the washer/dryer (if installed), after which the final product is carried to the end of the process, the collection table.

C.2 Controllers

C.2.1 HMI Panel – Main Page

Main screen to start the seamer motor and the belt. Also, controlling CIP, Top Up, Foam Valves, Lid Dispenser. Main Screen has integrated timers for better production monitoring while filling.



Figure 7 HMI Panel – Main Page screenshot



Button/Switch	Manual/Auto	Function
Manual/Auto	Both	Switches between auto and manual
CO ₂ Purge	Auto	Indicates when pre-purge is open
#1-5 Can Fill	Auto	Indicates when valves are open
Filler Stop Button	Auto	Normal stop of the filler operation in auto mode (seamer continues to run)
Lid Dispense	Both	Dispenses a lid
Clean in Place Indicator Switch (CIP)	Auto	Lights up when clean-in-place running; Turn the clean-in-place function on or off
Top Up Indicator Switch	Auto	Lights up when top up is running; Turn top up on or off, depending on position
Top Up Timer	Auto	Sets the amount of time the top up will last for
Foam Valves Indicator Switch	Auto	Lights up when foam valves running; Turn foam on or off, depending on position
Foam Valve Timer	Auto	Sets the amount of time the foam valves will be on for
Start Button	Auto	Start the equipment in auto mode; Lights up when running
Vibrator Off/On Switch	Both	Turn on the shaker or depal table vibrator

Table 2 HMI Panel – Main Page – Button Functions

C.2.2 HMI Panel – Filler Page

Manually Control Can Fill, CO2 Purge, Gate, Lid Purge.

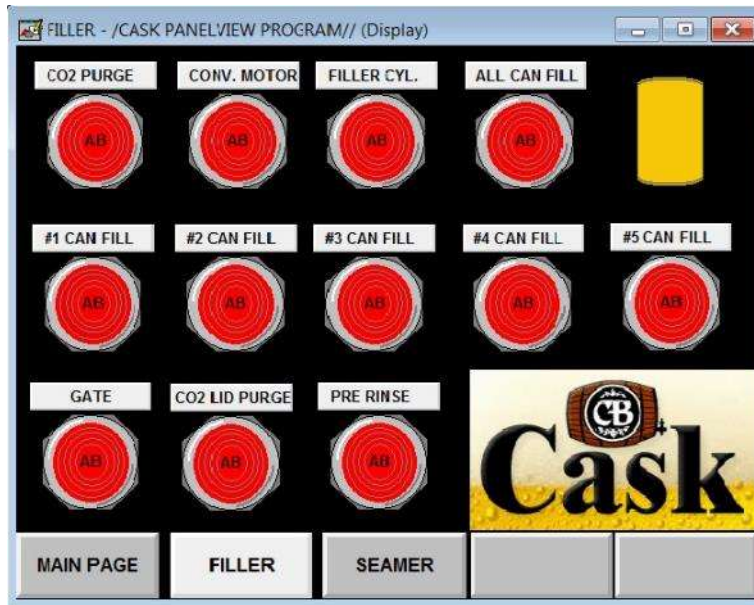

Figure 8 HMI Panel – Filler Page screenshot



Button/Switch	Manual/Auto	Function
CO ₂ Purge Button	Manual	Opens CO ₂ pre-purge
No. 1-5 Can Filling Buttons	Manual	Opens valves on both beer spouts at the numbered position
Gate Button	Manual	Opens can gate on conveyor
Conv. Motor Off/On Switch	Manual	Starts or stops the conveyer, depending on position
Lid Purge	Manual	Opens under lid gas purge
Filler Cylinder Button	Manual	When held down the fill head will lower fill head into the down position, when released the fill head will return up
Pre-rinse	Manual	Opens pre-rinse water supply
All Can Fill Button	Manual	Opens all 5 fill stations

Table 3 HMI Panel – Filler Page – Button Functions

C.2.3 HMI Panel – Seamer Page

Manually Control all aspects of the seamer. Table Up/Down, Die1/2 in-out, Push Cylinder #2, Seamer Motor Control.



Figure 9 HMI Screen – Seamer page screenshot



Button/Switch	Manual/Auto	Function
Seamer Motor	Manual	Turns seamer motor on
Table Cylinder	Manual	Operates table cylinder (up/down)
Push Cyl. 1	Manual	Operates can push cyl. #1
Push Cyl. 2	Manual	Operates can push cyl. #2
Dryer	Manual	Turns dryer on
Washer	Manual	Turns washer (post-rinse) on
Test Die #1	Manual	For testing 1st roll seam thickness
Test Die #2	Manual	To produce a test seam
Lid Dispense	Both	To dispense a lid
Die #1	Manual	Move seaming roll #1 in and out
Die #2	Manual	Move seaming roll #2 in and out

Table 4 HMI Screen – Seamer – Button Functions

C.2.4 Below Touchscreen

The emergency stop button is located under the touch screen for easy access.



Figure 10 Emergency Stop and Power Buttons

Button/Switch	Manual/Auto	Function
Emergency Stop Button	Both	Immediately stops the system from operating, and pneumatics return to their rest positions
Main Switch (behind machine)	Both	Main power supply switch

Table 5 Manual buttons located below the touchscreen

C.3 HMI Control Panel Operations

There are two different operating modes that the ACS can operate in and it is important to understand both of them, why they both exist and when you should be in which mode.

C.3.1 Manual Mode

Manual mode is generally used for setup and troubleshooting purposes. Most of the buttons and controls you see on the unit will only work while in manual mode. It allows for the discreet control of each individual operation and allows you to perform step-by-step operation of the machine to see and evaluate each process individually.

You would typically use this mode when adjusting the seamer or troubleshooting individual system functions.

C.3.2 Auto Mode

Auto mode is selected for either regular operation (filling and seaming cans) or CIP (cleaning the machine before and/or after use). While in Auto mode manual buttons on the three screens will not work, with the following exceptions:

1. Lid dispense (to allow you to replenish lids in the slide tray)
2. Top-up button (to allow you to turn top-up on and off and control the duration of the top-up (timer))
3. Foam valves (to allow you to turn foaming on and off and control the duration of the foam creation(with the timer))
4. Fill stop (to allow you to stop filling while continuing to seam remaining cans (filler will continue to fill cans that are in the filler but will not begin the next fill cycle, cans will continue seaming))
5. E-stop (to immediately cease all operation)

C.4 Electrical Panel Overview

C.4.1 Top Row of Breakers



Figure 11 Top row of breakers



Figure 12 Variable Frequency Drives (VFD's): #1 for main conveyor motor and #2 for seamer motor

Relays

1. SYSTEM AUTO SEQUENCE
2. SYSTEM MANUAL SEQUENCE
3. START CONVEYOR MOTOR
4. START SEAMER MOTOR
5. START DRYER SOLENOID
6. WASHER SOLENOID
7. PRE RINSE SOLENOID
8. CO2 PURGE LID DISPENSER
9. CO2 PURGE CANS
10. BEER VALVE 1A
11. BEER VALVE 2A
12. BEER VALVE 3A
13. BEER VALVE 4A
14. BEER VALVE 5A
15. BEER VALVE 1B
16. BEER VALVE 2B
17. BEER VALVE 3B
18. BEER VALVE 4B
19. BEER VALVE 5B
20. FOAM VALVE 1
21. FOAM VALVE 2
22. FOAM VALVE 3
23. FOAM VALVE 4
24. FOAM VALVE 5



Figure 13 Relay wiring diagram

C.4.2 Beer Manifold

- Beer should be carbonated to 2.4 to 2.9 volumes of CO₂ (or 4.6 to 5.6 g/L).
- Beer Temperature of 0 – 2C or 32 – 35.6F (colder for higher CO₂ volumes).
- CO₂ supply to bright tank should be set at 13 – 15 PSI (depending on CO₂ volume, temperature and distance from dispense tank).

In order to fill a can, the first step required is to have your product connected to the machine. The manifold allows a single hose line (1.5" tri clamp connection) to be connected from your tank to the machine, and then splits it ten ways to supply each valve in the fill head. The valves are rated to a maximum pressure of 24 PSI, so it is important not to exceed that line pressure or fill valves will fail to open. In Figure 14 you can see the two sets of five supply lines that are connected to the valves in the fill head, as well as the single supply line from the tank.

Best practise is to install a temperature and pressure gauge on the end of the beer manifold to allow monitoring of temperature and pressure of the beer at the delivery point to the machine.



Figure 14 Beer Manifold

C.4.3 Fill Head Manifold

The gate downstream of the fill head stops the cans creating a backlog all the way to the shaker table (Figure 15). This backlog is important as the spacing of spouts in the fill head are based on the cans being right up against each other. There are 10 cans under the fill head. The last 5 are purged with CO₂ as the first five (already purged) are filled with beer. After the fill is complete the head retracts to the up position and the gate opens. The sensor immediately upstream of the gate counts 5 cans before re-closing the gate and beginning the next fill cycle.



Figure 15 Can Gate downstream of fill head

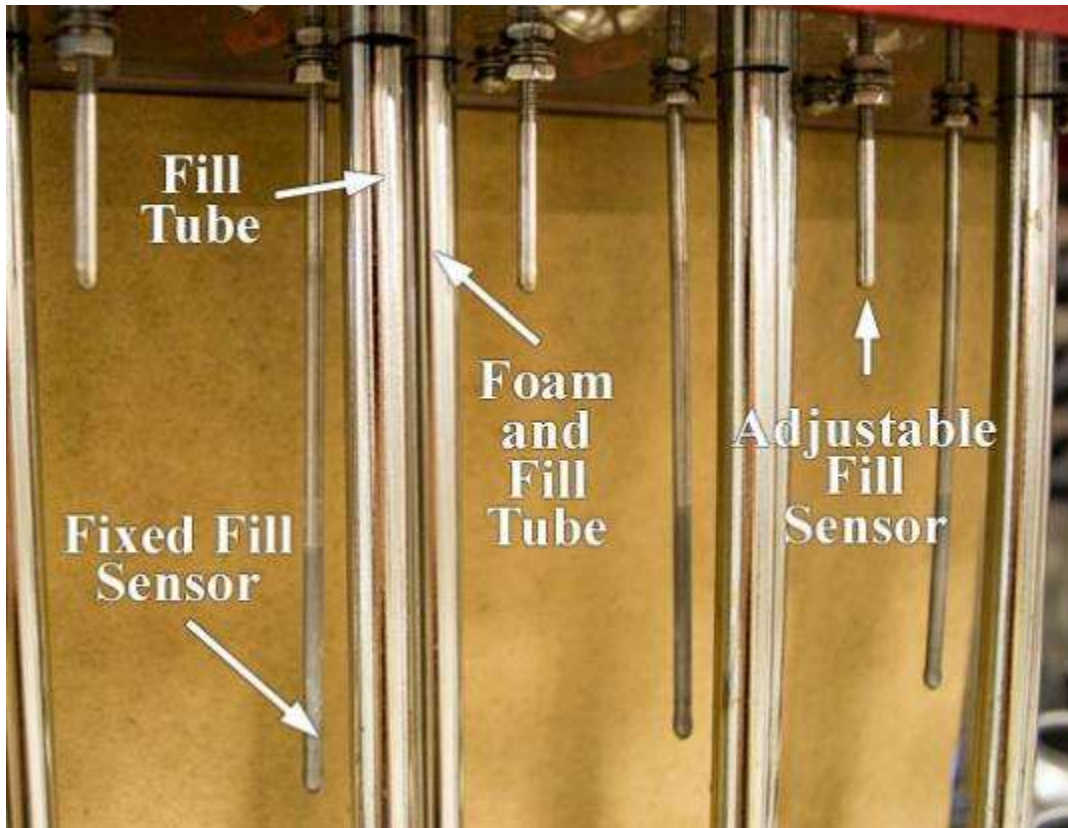

Figure 16 ACS fill head showing fill sensors, foam tube and fill tube.



C.4.4 Foam Valve and Top Up Setting

C.4.4.1 Foam Valve & Button

- In order to keep air pick up to an absolute minimum the beer must be foaming when it leaves the filler until the lid is applied at the lid applicator. Generally the level of foam should be at or over the top of the can rim when the lid is applied.
- If the foam level on the beer is low, additional foam can be created by activating the foaming valve.
- When the foaming valve button is turned on, the timer below this button controls the length of time that the foam valve will create foam. Generally, only a very short setting is required to create foam. We set this at 0.1 to 0.2 seconds to begin. Run through several beer fill cycles to establish whether the foam is sufficient before increasing the timer setting. To set timer: press timer button, enter time, hit enter button to save change. Timer can be changed at any time during operation – the new time will not take effect until the next fill cycle starts.
- **Note:** Never turn the foam valve button on or off while the fill valves are open and filling. This will cause a malfunction of the level sensors.

C.4.4.2 Top Up Setting

- When the **Top Up** button is turned on the fill valves will shut off as usual when the level sensors detect foam BUT – they will reopen for a period of time – determined by the adjacent top up timer – while the valves are being withdrawn from the can.
- This **Top Up** function gives the operator further control of the final fill level of the can. The beer that leaves the fill spout as the spout is rising with the fill head replaces the volume of the spout itself – raising the final fill level. This may prove necessary with beers that are excessively foamy during the fill, leaving too much head space in the can once the initial foam recedes. The top up function can also be used to create a small amount of additional foam (due to the turbulence created as the beer flows into the filled can) to beers that foam too much when the foam valves are used.
- To operate: turn the foam valve on when the fill heads are at rest. Set the timer to 0.25 seconds. Run a few can fill cycles to gauge the effect. Increase the time interval as required.
- **Note:** When setting interval on top up timer, be sure that beer valves are not still open (verify visually during operation) when the valve has exited the top of the can as this will result in oxygen pick-up.

C.5 Can Filling

The two primary functions of your canning system are filling an empty can with beer, and seaming a lid onto the filled can. This section is a useful reference understanding how the machine accomplishes these two functions. It is necessary to understand the filling process and your choices associated with it regarding foam. The seaming process is very important to the on-shelf quality of your product. Without the proper seam in place your cans could leak, spoil, or go flat before the beer gets to the customer resulting in wasted product and decreased revenues. For this reason it is very important to both understand the seaming process and how to evaluate your seams once made.

As previously discussed under Section C.4.2 Beer Manifold (page 16), the first step required is to have your product connected to the machine. The beer passes through the manifold to the ten valves in the fill head. The first five empty cans stop directly beneath the fill heads five fill stations. Each station has two fill spouts, one with a foam valve, one without, and a fill level sensor. The fill head then drops down inserting both spouts and sensors into each can. If you desire more foam in the can, set the system for it with the foam timer on the HMI Panel. The switch must be set to the on position and the desired foaming time set on the timer dial. When the foam button is on the fill sequence begins with a burst of foam from the foam valve for the duration set on the foam timer. Regular filling then continues until the cans are full. Once the beer/foam level reaches the sensors the corresponding valves will close and filling will stop for that fill station.

Each station has independent sensors to compensate for slight variances in fill time. Once all five sensors read full and all fill spouts have stopped, the head rises out of the can and the gate opens allowing five cans to pass through it.

C.6 Lid Dispenser

The lid dispenser holds the lids at the optimum angle for contact with the cans passing underneath on the conveyer – refer to 1 in Figure 17.

The leading edge of each can grabs and pulls a lid out, which falls into place on top of the can, as it passes. CO₂ is dispensed beneath the lid to purge air from the top of can. A new lid is dropped into the tray for every can that comes into contact with the position sensor at #1 push cylinder.

Lids can be manually dispensed using the “Lid Dispense” button on the Seamer Panel (see Figure 9 on Page 11).

For more information regarding adjustment and troubleshooting, refer to Section D.8.1 Lid Dispenser Adjustment & Troubleshooting on Page 27 and D.9.2 Lid Dispense Troubleshooting on Page 34.

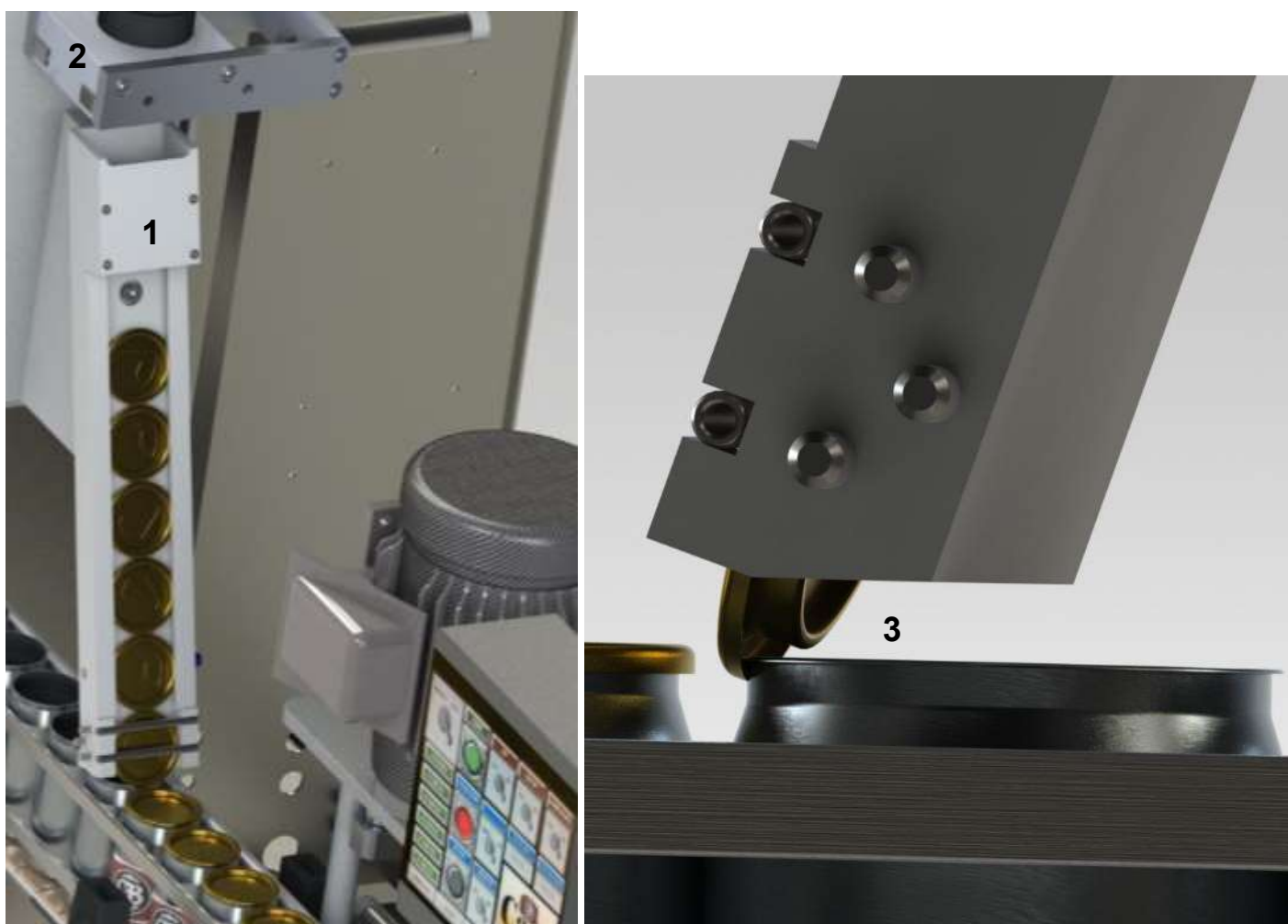

Figure 17 Lid dispenser

C.7 Parts in Motion: Pneumatics

All of the cylinders on the machine are run pneumatically. Having a general understanding of how these are set up is important. The actuators, valves, and most of the regulators are contained behind the back panel of the equipment. With the door open you will see something similar to the Figures below.

A total breakdown of the pneumatic devices on the machine, which have been mentioned previously in C.1 System Operation Walkthrough, are as follows:

- Shaker Table Lift Cylinder
- Fill Head Up/Down Cylinder
- Lid Dispenser Cylinder
- Gate Cylinder
- #2 Push Cylinder
- #1 Push Cylinder
- Die #2 (2nd op seaming roll)
- Die #1 (1st op seaming roll)
- Seamer Lift Table



Figure 18 Pneumatic Connections

Air enters the system at the primary regulator (Figure 19). The primary regulator is located outside of the back cabinet and should be set to 90 PSI.

All of the devices and cylinders are controlled through the actuator bank. Each actuator has two air lines coming out of it and into the front and back of an individual air cylinder on the system. The rate of flow through each cylinder is controlled by an airflow control screw (Figure 28).



Figure 19 Primary regulator

C.8 Parts in Motion: Motors

All systems consist of two motors.

- Mounted on the conveyor tunnel of the machine, there will always be one motor that drives the conveyor (Figure 20 - #1)
- On top of the seamer assembly is the motor that turns the chuck. (Figure 20 - #2)



- There should be no adjustments needed to any of these motors after initial installation.

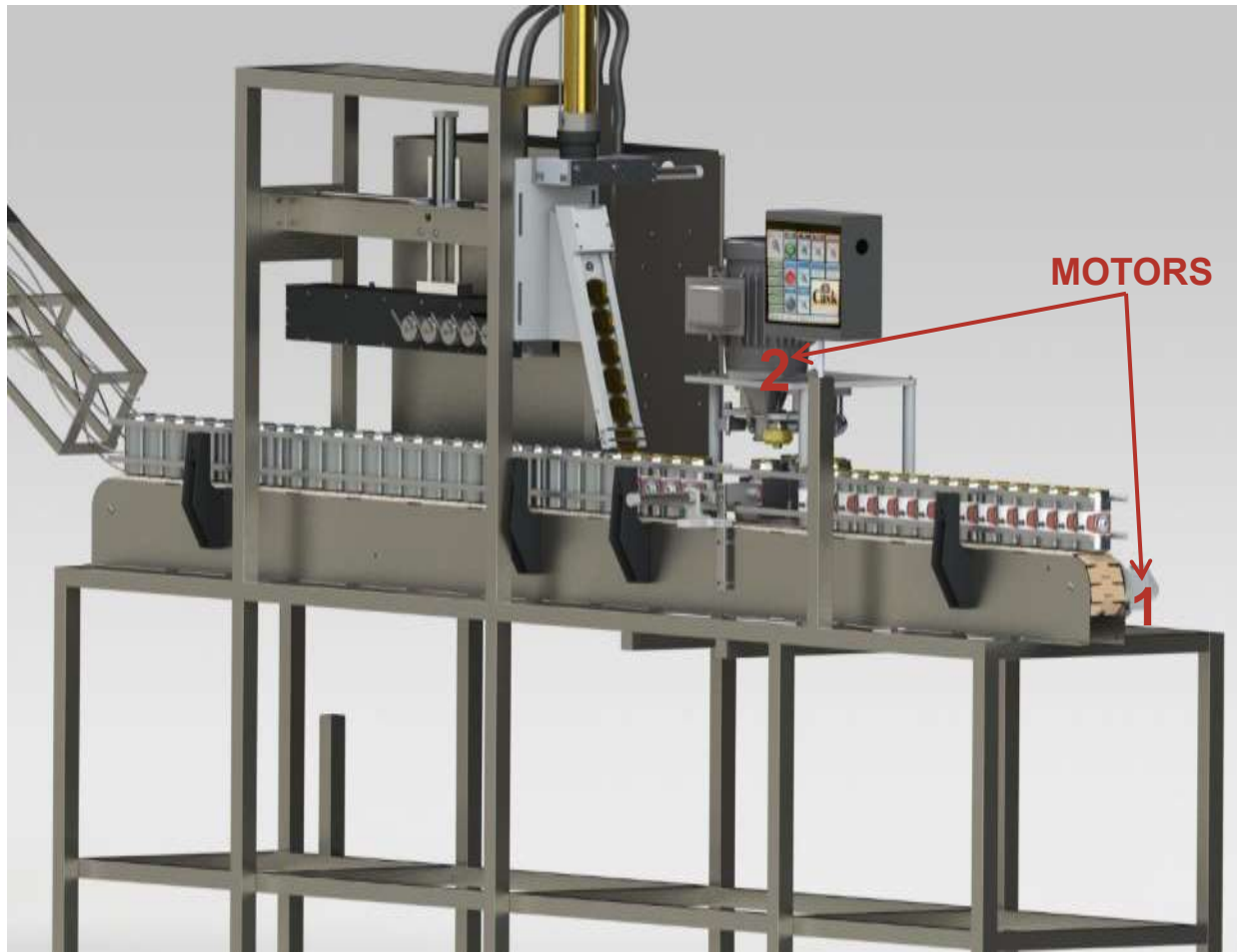

Figure 20 The ACS has two motors to drive the seamer and the main conveyor



Section D. ACS System Operations

D.1 Initial Start-up Adjustments & Settings

Your Cask canning line has been factory tested prior to shipping to allow for trouble free installation by a Cask Technical Representative at your site. Follow these steps to ensure optimum operation.

Locate and familiarize yourself with the following system components:

- Control Panel (Touch Screen)
- Air Input Valve and Pressure Regulators
- CO2 Input Valve and Pressure Regulators
- Can Line Guides
- Conveyer Sensors & Clearance
- Fill Head Manifold
- Fill Head Gate
- Lid Dispense Button
- CO2 Delivery Areas
- Push Cylinder #1
- Push Cylinder #2
- Rinse and Blower Operation
- Receiving Table Delivery

D.2 Pre-Start Checklist

Verify the following before starting the system.

- Air inlet valve is open, air is connected and air supply (compressor) is on.
- Air supply is dry – Check that primary air filter is dry (bleed air from drain nozzle).
- Air pressure regulators
 - Set primary pressure at 90 PSI.
- CO2 pressure regulators: first regulator 12 – 15 PSI, second regulator 0.5 – 2 PSI.
- CO2 delivery – Check and verify CO2 dispenses from purge tubes and lid dispenser slide.
- Water inlet valve is open. The regulator should read 22 PSI (applies to models with rinser/dryer and/or pre-rinser).
- Beer header input pressure and head pressure on the tank should be within 1 to 2 PSI differential pressure of each other to ensure consistent fill levels.
- Conveyor guides - Cans travel freely on conveyor (no binding)?
- Sensors – Cans counting correctly through fill manifold section?
- Lid dispenser operation – Lid sleeve full? Are lids loading correctly (face up) into lid slide?
- Seamer entry push piston actuation okay?
- Is lid dispenser actuating with each can that passes the sensor at the seamer entry push piston?
- Seamer system – Lift table, die 1&2 operator satisfactory?
- Exit push piston actuation okay? (Ensure can is not in exit position when starting or restarting system or jam will occur.)
- Rinser and blower working (test in manual mode)?
- Receiving table delivery – Cans sliding onto receiving table entry tab smoothly?
- Beer carbonated to 2.4 to 2.9 v/v of CO2 (or 4.6 to 5.6 g/L)..
- Beer Temperature 0–2 deg. Celsius at the manifold (32 - 35.6deg F. Colder for higher CO2 volumes).
- Ensure CO2 supply to bright tank is properly set (as required 13 – 15 PSI – or higher for longer distance runs to compensate line loss).



D.3 Startup & Operation

To start up your ACS:

- Turn power on main panel on.
- Flush system manually with beer until foam disappears from each valve head.
- Turn vibrator motor on.
- Check lid dispenser.
- Press start.

D.3.1 Ongoing Operational Checks

Things to monitor while operating ACS include:

- CAN JAMS, misfeeds, etc: IMMEDIATELY hit either E-stop button (HMI). Clear the fouled cans. Remove any cans that might have been crushed by the conveyor gate. Place a seamed can on the can lift table (to prevent cans from 'walking' on to platform during seamer start up delay). Ensure cans on conveyor are properly centered under the fill tubes. Reset the E-stop button. Press Start.
- Verify cans are entering the conveyer smoothly.
- Watch cans fill and inspect for over foaming and under fills.
- Verify lids are dispensing onto cans as they pass under lid slide. If lids 'miss' a can, pull a lid manually from the bottom of the lid tray and place on can before it reaches the pre-load position (in front of Push Cylinder #1).
- Verify lids continue to dispense into the slide top-side-up.
- Monitor lid sleeve level from time to time to ensure you don't run out during the canning process.
- Check can weights for proper fill levels as often as possible. Records of the weights should be kept.
- Full can seam tear down should be done prior to production every day. Can seam height and width should be checked frequently (once every three to five minutes) throughout production. Production should be stopped if there is a change of more than 2/1000 on either dimension. A full seam tear down should be performed to determine the cause of the change and the adjustments required. The procedure for checking the quality of your seams is a "Can Seam Tear Down". This enables you to make various measurements as outlined in Section E. Seam Measurement on Page 37.

D.4 Clean in Place (CIP) System

The system is designed to be relatively maintenance-free. With simple, regular cleanings it should run optimally. However, with this in mind, it is critical to ensure the equipment is thoroughly cleaned every shift. Due to the sugar content in the beer it is very sticky when it dries, and this can affect the functionality of some of your moving parts if it is allowed to dry on them before being cleaned. A proper cleaning should focus on all the splash areas, including the seaming station and fill location under the lid dispense tray (critical!) but also include the rest of the machine as well.

Use a hose to spray down the whole system and then compressed air to dry as much as possible. What can't be dried with air should be wiped down with paper towel or a clean, dry cloth. If you follow this simple cleaning process your machine will run smoothly with fewer service issues and production interruptions. Refer to this maintenance schedule for an easy way to keep track of what needs to be done to keep your ACS running as best and as long as possible.

PLEASE ENSURE ALL PARTIES INVOLVED IN CLEANING ARE WEARING PROPER PPE (PERSONAL PROTECTIVE EQUIPMENT).



Maintenance to be Performed	Frequency
Thoroughly clean equipment	Daily or after every use
Check conveyer track tension, remove links if necessary	Quarterly
Replace beer hose	Semi-Annually

Table 6 Regular Maintenance Summary

D.4.1 CIP Procedure

CIP mode is designed to allow the continuous flow of water and cleaning solution through the system. As such, when the selector switch is in Automatic mode CIP will not work when the switch is in manual mode and CIP is turned ON, the fill sensors that normally turn the fill heads off are disabled. Cans can be placed under the 5 fill heads and when the start button has been pushed, product will continue to flow even after the fill sensors have been contacted by liquid.

In addition to this, the filler will cycle into 'foam' position once every 80 seconds to clean the inside of the foaming valve holes. The fill heads will then cycle off for 20 seconds to allow the fill valve coils to cool before cycling on again. This will prevent the coils from overheating and potentially burning out. This sequence will be repeated for 30 minutes until the stop button is pushed.

Notes on CIP:

- Pressure – when flushing the system with water or cleaning solutions it is important to keep pump pressures below 24 PSI. The fill valves will not open at pressures higher than this level. If the valves are over pressurized and jammed shut the beer line will have to be de-pressurized before the valves will open again. For breweries with automated CIP systems or large pumps on CIP reservoirs it will be necessary to use a by-pass valve to reduce CIP feed pressure.
- Temperature – when flushing the system with hot caustic for cleaning it is advisable to 1) keep solution temperatures at 65 degrees Celsius or lower.

D.5 ACS Post-Operation Shutdown Checklist

Verify the following steps have been accomplished before placing system in dormant mode

- Run CIP (see D.4 Clean in Place (CIP) System)
- Clean all exposed surfaces with hot water and sanitizer solution (peracetic acid, iodophore, etc.)
- Air inlet valve closed?
- Primary filter purged?
- CO2 inlet valve closed?
- Water inlet valve closed?
- Control panel power off?



D.6 System Periodic Maintenance

The ACS system is designed to be relatively maintenance free. With the PM (Periodic Maintenance) schedule and simple, regular cleanings, it should run optimally.

Frequency	Maintenance Job
Daily	<ul style="list-style-type: none"> Clean canning system with a sanitizing solution.
Quarterly	<ul style="list-style-type: none"> Check conveyor belt for wear and tear. Remove length if necessary. Inspect bearings. Nut and bolt torque checks.
Annually	<ul style="list-style-type: none"> Clean air regulator filter bowls. Replace beer lines and beer valve o-rings every 1500-2000 hours of operation.

Table 7 Recommended System Periodic Maintenance Schedule

D.7 Parts List

The below Parts List in Table 8 gives the Part Number and Description for common ACS parts to allow easy communication for reordering part or troubleshooting with our support center.

Part Number	Description
R 275557	Coil 24 DC-foam coil
R 275519	Coil 24 DC beer coil
PX1 E1 A3265/S	Electric single mix tap - no spout
R 990004/G	O ring (medium) for 7 mm inlet on fill valve
R 990704 N 1	O ring (small) for tap spout - inside
R 990015 N 2	O rings (large) for tap spout - outside
FES DSNU2599PPVAMQQTXT	Festo, Can Push #1 Air Cylinder (99mm)
FES SMT8MANS24VE03M	Air Cylinder Proximity Limit SENSOR
CBS NOZ PRERINSE	Plastic nozzles adj mist spray for ACS rinser (100pcs/bag)
SETSCR SEAM ROLL	Seam roller adjust set screw w. nylon tip
FES ADVUL-40-25-P-A	Festo seam table air lift cylinder
FES DSNU-40-13-P-A-TXT	Festo seam roller air cylinder
FES GRLA-1/4-QS-6-D	Flow control air valve 1/4" (193146)
FES GRLA-1/8-QS-6-D	Flow control air valve 1/8"
BRG CAN TABLE	Can lift table bearing SS
BRG SPINDLE	Bearing SS for Can Seamer Spindle
ALB 700-HK36Z24-4	Allen Bradley Relay 24VDC
SEAM MAN ANG	Angelus can seam manual

Table 8 ACS Parts List with description and part number

The below exploded view Figure 21 and Figure 22 are provided to allow easy identification of parts for reordering or troubleshooting with our support center.

- Figure 21 below contains an exploded view of the 1) Seamer Pivot Shaft Assembly and 2) Can Table Mount Assembly is to allow you to easily identify parts for reordering.
- Figure 22 contains an exploded view of 1) Seamer spindle and 2) a labelled view of the seaming roll

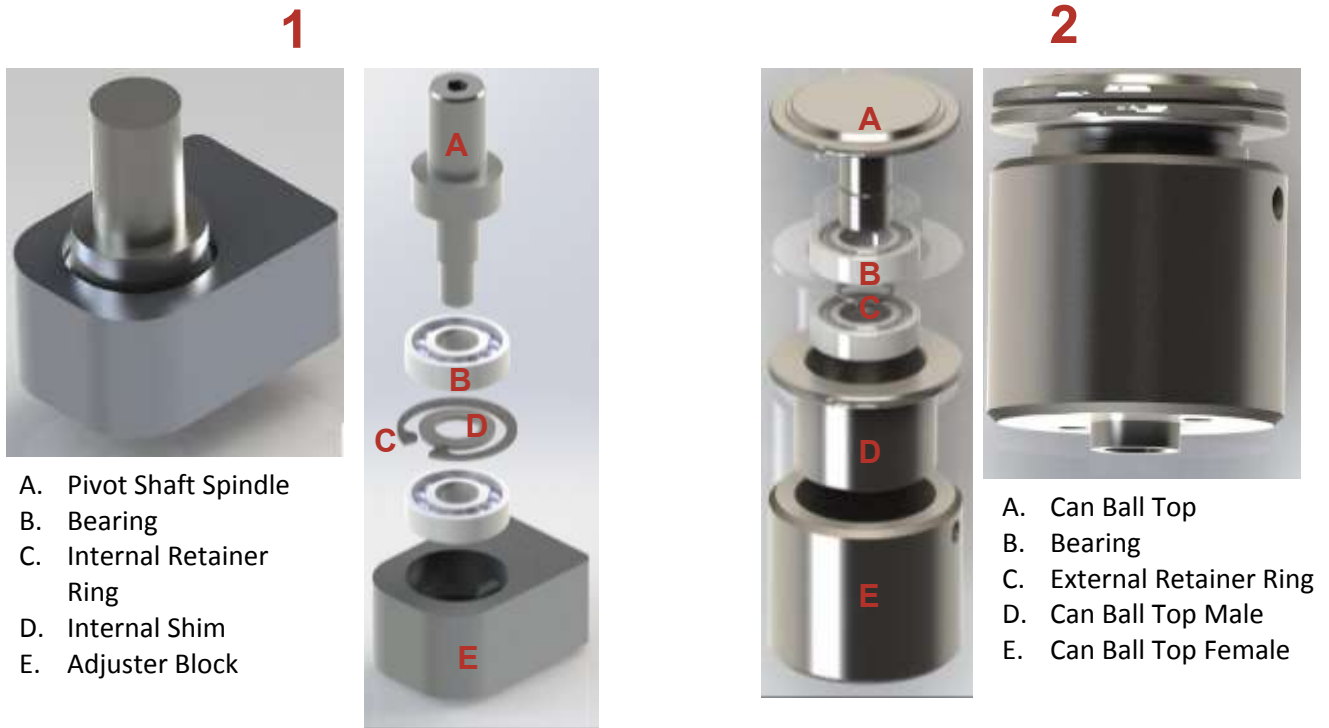

Figure 21 Exploded view of seamer pivot shaft assembly (1) and can table mount assembly (2)

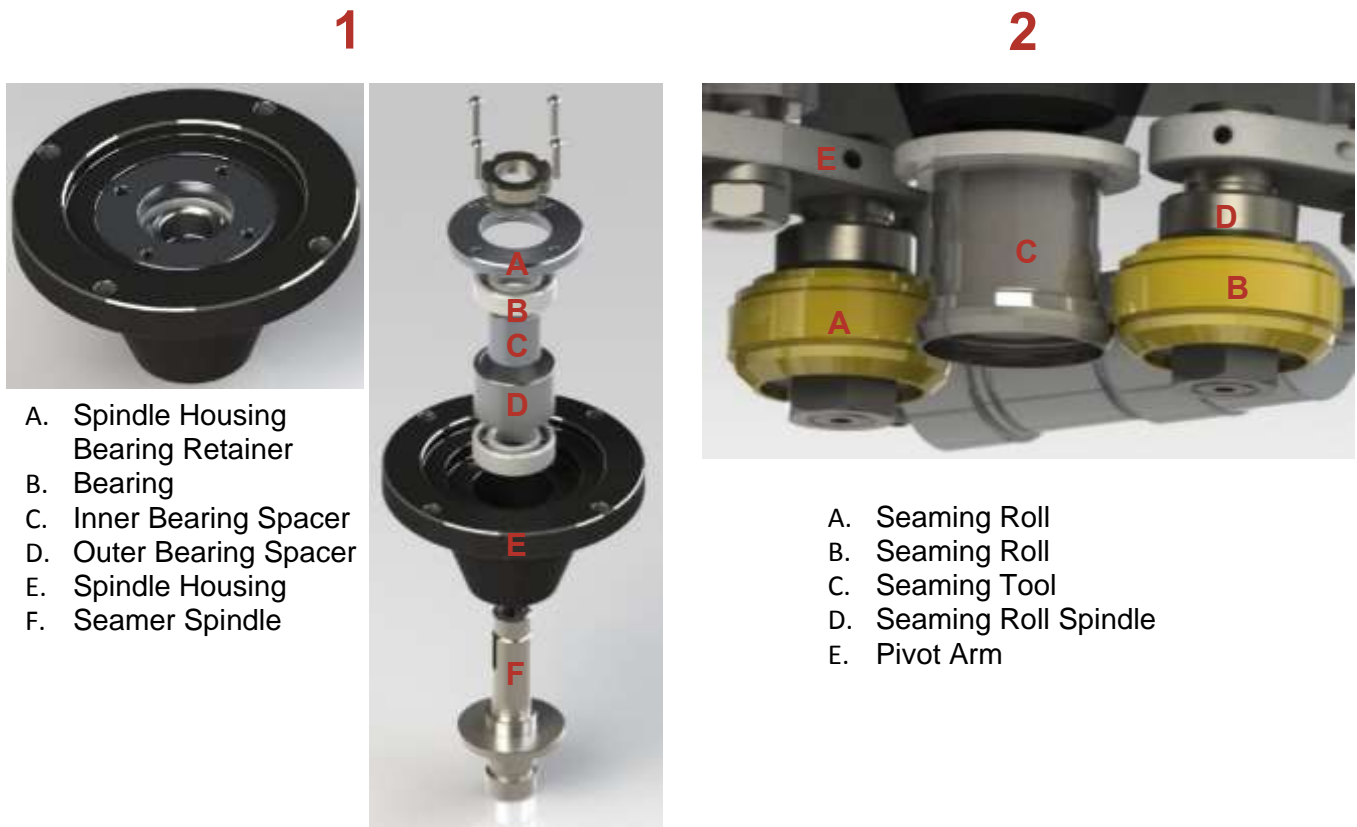

Figure 22 Exploded view of (1) seamer spindle house assembly and labelled view of (2) seaming roll

D.8 Adjustment & Troubleshooting

D.8.1 Lid Dispenser Adjustment & Troubleshooting

Tools Required

- 7/16 wrench

D.8.1.1 Problem #1

Symptoms

- Lid not releasing from bottom of slide correctly.
- Lids not catching can.
- Lids not automatically refilling.

Adjustment Points

- If cans tip over after lid application, loosen rubber band tension.
- If can lids drop frequently with no cans in place, tighten rubber band.
- Figure 23 shows set bolts for adjustment of can lid dispense height.
- Set screws under the retaining bars.

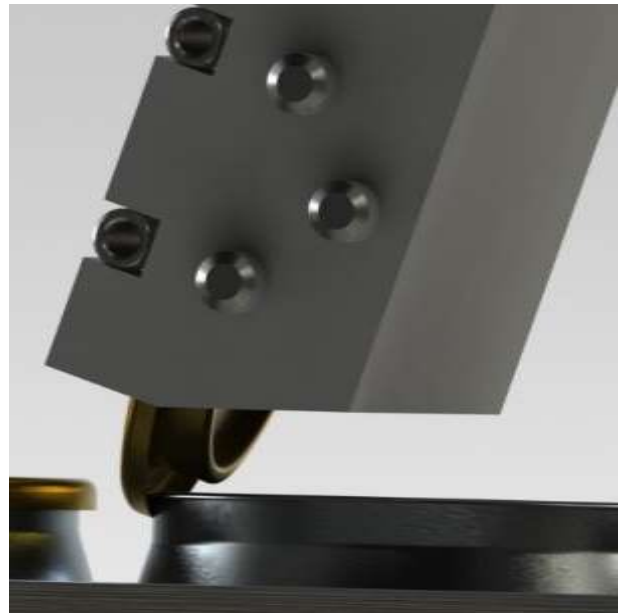

Figure 23 Setting bolts to adjust can lid dispenser height

D.8.1.2 Problem #2

Symptoms

- Lids enter the tray upside down
- Lids bounce off and fail to enter the tray

Adjustment Points

- Check the orientation and position of the hopper and tray. It should be positioned as below in Figure 24.

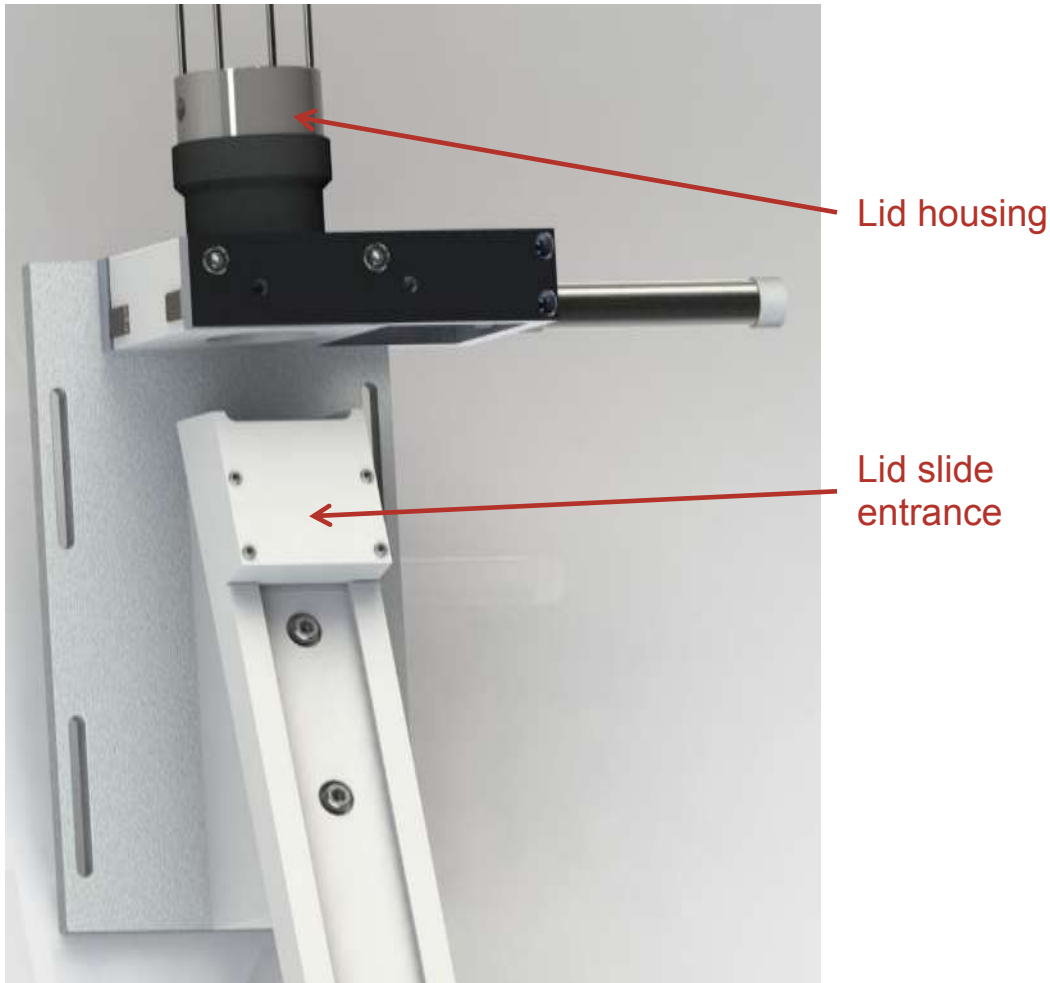

Figure 24 Ideal lid dispense hopper and tray configuration

D.8.1.3 Problem #3

Symptoms

- Lids miss the can – fail to ‘grab’ the can as it passes by on the conveyor

Adjustment Points

- Check for proper height of Lid Dispenser Slide (see Figure 25).
- If height is found to be incorrect: Loosen $\frac{1}{4}$ " Bolts and carefully adjust to suitable height to catch lid with can.

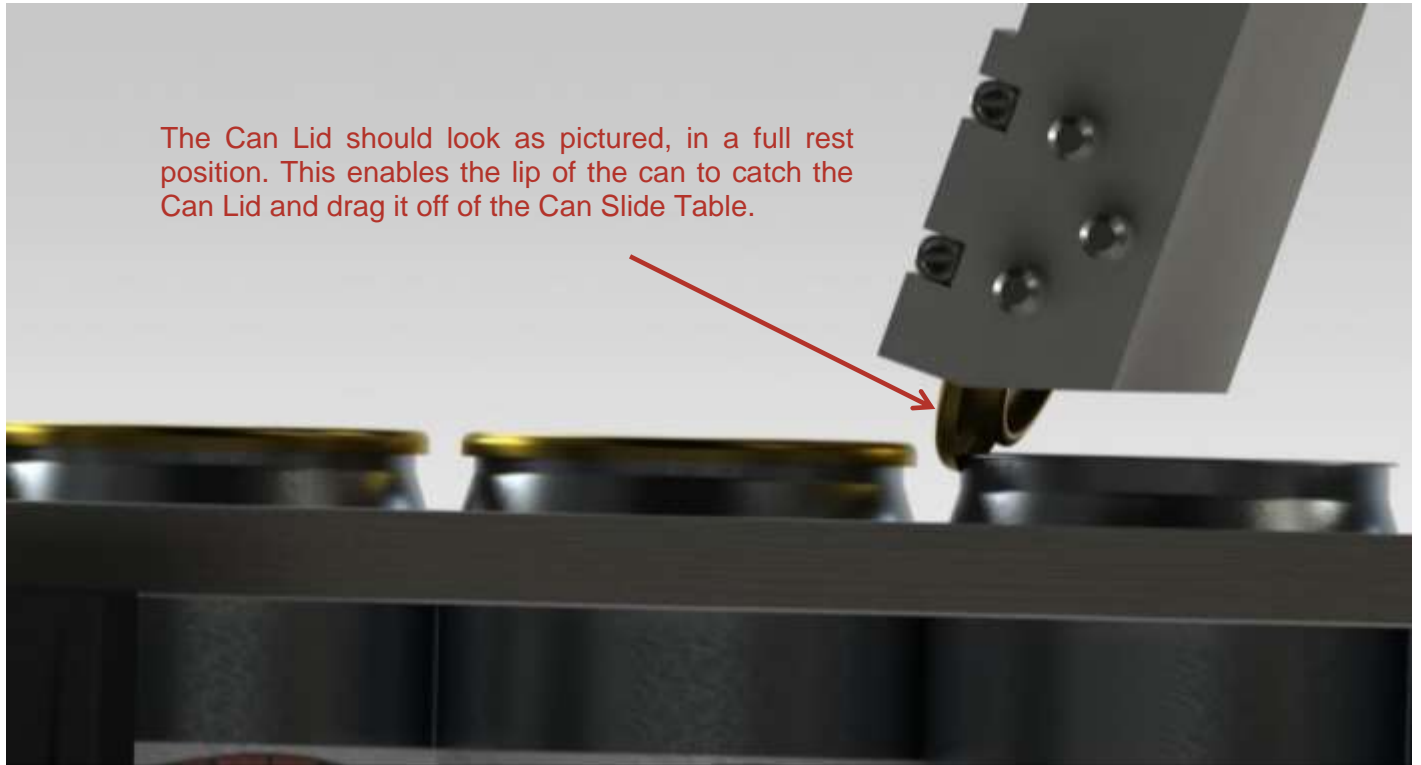

The Can Lid should look as pictured, in a full rest position. This enables the lip of the can to catch the Can Lid and drag it off of the Can Slide Table.

Figure 25 Ideal can lid dispensing diagram

D.8.2 Air System Adjustment & Troubleshooting

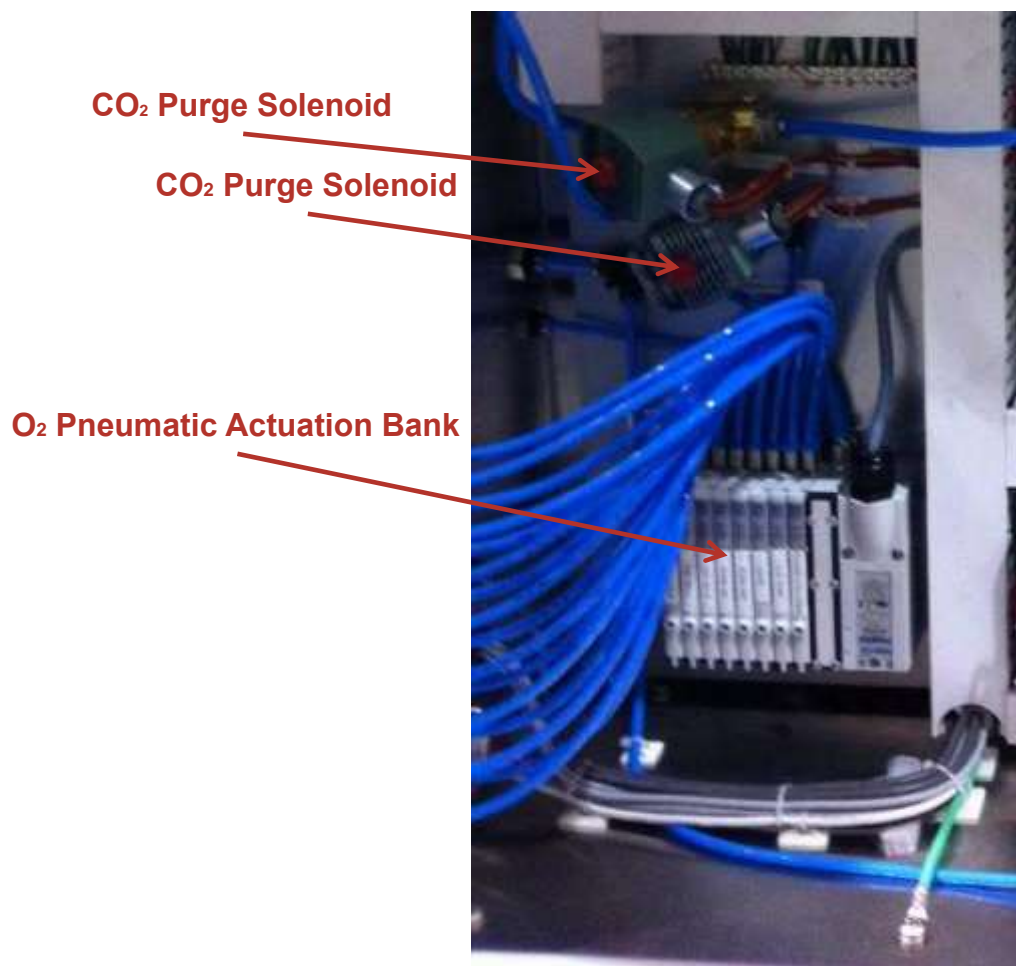

Figure 26 ACS Pneumatic System Overview

- All actuators are labeled as to their control function.
- If pneumatic cylinder is not functioning, check for cracked air lines, if no cracks are found go to the air bank and depress the corresponding actuators button to manually override the corresponding pneumatic cylinder.
- If you are unable to manually override the air bank, this is possibly a result of a bad/malfunctioning partition of the bank itself.
- To test a possible bad partition, remove and swap with a mating partition. If the problem moves to the swapped out part, you have a bad partition and need to replace.



Air Actuator Bank

**Pneumatic Air Bank
Manual Over Ride Buttons**

Figure 27 Pneumatic air bank manual over ride buttons

D.8.2.1 Air Cylinder Speed Adjustment

The airflow control screw on the front of the cylinder controls the rate of air flow, and this the speed of operation of the cylinder as it extends. The airflow control screw on the back of the cylinder controls the speed of the retraction stroke.

Dialling either of these screws in a clockwise direction will slow the stroke. Dialling counter clockwise will speed up the stroke. Turning the flow control clockwise will close the airflow control, thereby slowing motion down.

Conversely, counter-clockwise will open the airflow control, speeding motion up. All of the solenoids are labeled as to which cylinder they control. This becomes important when setting up the system and setting the timing. Typically these should not require adjustment once initial setup is complete.

All adjustments are to be made on the cylinders themselves (see Figure 25).



Figure 28 Adjusting air flow control screws on seam station air cylinder

D.9 Frequently Asked Questions

D.9.1 Seamer Troubleshooting

D.9.1.1 Cans stumble

Problem Symptoms

The cans pitch forward as they are being transferred from the conveyor to the slide table. Lids slide or fall off frequently before they reach the can lift table.

Solution

- Check the alignment of the slide table with conveyor. When sliding a can by hand from one to the other there should be no detectable bump (i.e the slide table should be at the same height as the top of the conveyor belt).
- Adjust the height of the slide table by loosening the nuts on top (Figure 29 Photo 1), and raising or lowering, as required, the nuts on the bottom (Figure 29 Photo 2). Retighten the top nuts.
- If the stumble is occurring at the can lift table it may be necessary to adjust the height of the height of the can seamer relative to the slide tray table.
- **NOTE:** do NOT adjust the can lift table height as this will affect the can seaming process and the specs on the can seam.
- Also check that the cans are not over-filled.
- Also check that push arm #1 is not moving too quickly. Try slowing down the extension of the cylinder to see if the problem abates.

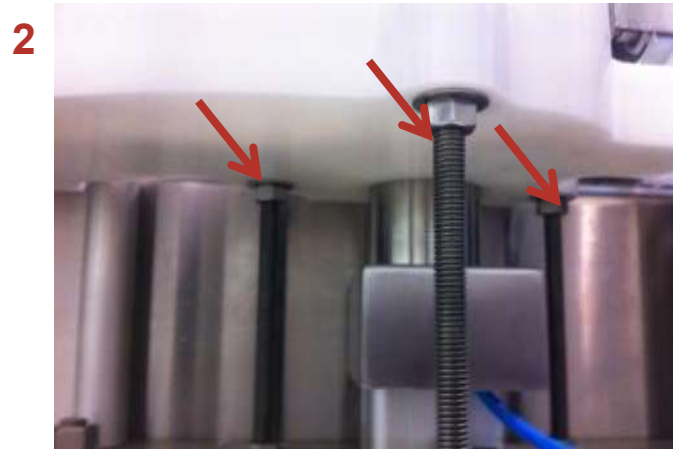
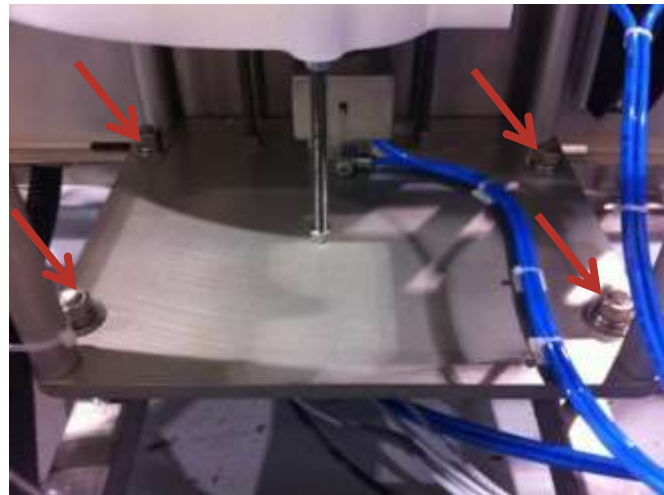

Figure 29 Adjusting height of the slide table

- The entire seamer must be raised or lowered as follows (depicted in Figure 30):
 - Loosen the nuts on the top of the base of the seamer table (Figure 30 Photo 1).
 - Raise or lower the seamer platform by turning the nuts underneath the seamer base plate (Figure 30 Photo 2).

1



2



Figure 30 Adjusting the height of the entire seamer assembly

D.9.1.2 Cans misfeed and crush against chuck during seaming

Problem Symptoms

The can appears to load crooked, lopsided, or incompletely and is not centered when the can lift table rises, resulting in the can crushing against the chuck as it rises.

Solutions

- Check the alignment and position of Push Cylinder#1.
- If extensive can jamming has occurred, or the push cylinder has been bumped by an operator or equipment, the alignment of the cylinder can change. In manual mode, test the length of the stroke: with a full can in place press and hold the push cylinder #1 button and verify that the can is being delivered all the way onto the can lift table.

A stroke that is too short or too long would result in improper position of the can when the seam cycle begins which will result in a can crush. Check also that the can is centered.

D.9.1.3 Can does not feed onto seamer

Problem Symptoms

Can arrives in the load position (end of conveyor where push arm #1 is) but the push arm does not activate to load the can onto the seamer.

Solutions

- Check that the CIP button is turned off
- Check the proximity sensor that is mounted in the 'end stop'. It may need to be advanced in the block in order to detect the can. Loosen set nut and turn the sensor so that it advances in the block, then retighten the set nut.
- Check the sensors on the front and back of push arm #1. There is a sensor on each end of the cylinder and they each have an LED light. When the sensor is at rest the back sensor light should be illuminated. If it is not, the sensor has been misaligned and it needs to be shifted forward or backward on the cylinder body until the light stays illuminated.

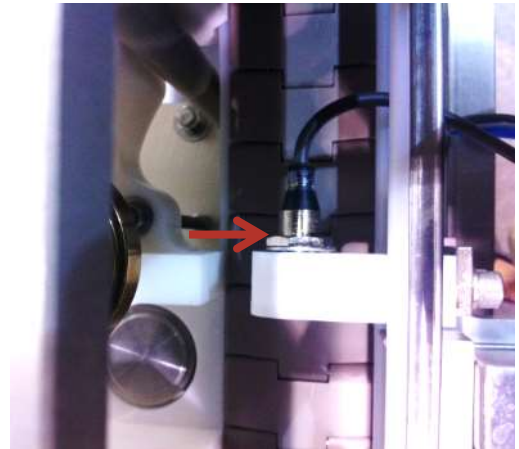

Figure 31 Proximity Sensor

D.9.1.4 Push arm #1 does not retract

Problem Symptoms

Push arm loads a can on but then stays in the fully extended position – won't retract.

Solutions

In manual mode, press the push arm #1 button and hold down. Check that the front sensor LED light (yellow) remains illuminated until you take your hand off the button. If it is not illuminated, the sensor has to be shifted forward or backward on the cylinder body until the light stays illuminated.

D.9.2 Lid Dispense Troubleshooting

D.9.2.1 Can lids drop through the end of the lid slide

Problem Symptoms

Lids frequently fall out of the slide before a can arrives.

Solutions

- Check the position of the lower metal retaining bar – it may have popped out of the recessed groove in which it should be positioned AND/OR the elastic tension may need to be increased

D.9.2.2 Cans topple at lid dispenser

Problem Symptoms



The can lid hooks onto the can but topples the can rather than releasing onto it as it passes by.

Solutions

- The tension on the lower elastic is too high – loosen elastic tension OR
- The cans are under filled – try to reduce foaming in the cans. If the machine has been stopped for any length of time there may be warm beer in the lines that is causing under filling. Bleed the warm beer out until foaming stops and then start again. If cans are still under filled, see D.9.3 Filler Troubleshooting on Page 35.

D.9.2.3 Can lids jam at the top of the lid feed slide

Problem Symptoms

Frequent jams occur with multiple lids accumulating in the top of the lid slide.

Solutions

This usually arises because of a miscount of lids when starting after an e-stop due to can jams or misfeeds.

- When there are no cans on the conveyor waiting to be loaded on the seamer there should be 6 or 7 ends in the lid slide.
- However – if there are cans (with lids on them) waiting to be seamed when you press the start button, you must deduct one lid from the lid slide for every can that is waiting to be filled.
- A new can lid is dispensed into the lid slide for every can that touches the sensor at the end of the line. If you start with too many lids in the lid slide it can overflow which will cause a jam at the top.
- ALWAYS count the lids in the slide prior to restarting after a can misfeed.

D.9.2.4 Cans stick in lid slide or do not fully descend. Lids miss the can.

Problem Symptoms

Cans stick in lid slide, do not fully descend or lids miss the can altogether.

Solutions

1. Clean lid slide. There may be debris or beer in the lid slide that needs to be removed.

D.9.3 Filler Troubleshooting

D.9.3.1 Fill head does not descend when cans are in place

Problem Symptoms

Fill head does not descend when cans are in place.

Possible Causes & Solutions

1. Count-in sensor did not count 5 cans. Press the start button. If the head descends immediately this is a counting sensor issue. Occasionally cans may pass the sensor without being counted, particularly if they have a slight indentation in them causing them to miss the sensor. If this happens frequently (several times an hour or more), it may be necessary to reposition the count-in sensor. Loosen the nuts that hold it in place and thread it into the plastic holder so that it is closer to the cans as they pass by. Retighten.
2. If pressing the start button has no effect check the sensor on the top of the fill head air piston. The green light on the sensor should be on. If it is not on, try repositioning the sensor (move it up or down until the light comes on



and stays on). If the light does not come on while there is power to the machine (e-stop is not engaged) then the sensor may be defective and require replacement.

D.9.3.2 Fill descends, cans fill but do not stop filling

Problem

Fill head descends, the cans fill but the fill process does not stop.

Solution

Check that the CIP button on the main page is not turned to the 'on' position.

D.9.3.3 Fill head does not rise

Problem

Cans stop filling but can fill head will not rise.

Solution

Check the position of the sensor on the fill head air piston. Lower sensor light should be illuminated. If it is not illuminated fill head will not rise. Reposition the sensor (up or down on the air cylinder shaft) until the light comes on. If the light does not come on the sensor may be defective and require replacement.

D.9.3.4 More than 5 cans exit the filler after a fill cycle

Problem

More than 5 cans exit the filler after a fill cycle.

Solution

The count-out sensor is miscounting cans. One of two possible adjustments, or a combination of the two may be required:

- Adjust the position of the front guide rail of the conveyor so that it is closer to the back rail. The two must be as close together as possible without causing binding of the cans between the rails.
- If the rails are as close as possible after adjustment 1) then reposition the count-out sensor on its mounting bracket, by loosening the set nuts on either side of the bracket. Move the end of the sensor in closer to the cans and then retighten the set nut. To verify if the sensor is properly positioned, hold a can snugly against the front guide rail (not the back rail where the sensor is mounted) and slide it back and forth in front of the sensor while checking the sensor indicator light and verifying that it illuminates each time the can passes in front of it.



Section E. Seam Measurement

The process of seaming a can involves folding the lip found on the top edge of the empty can body, into the lip of the lid. This results in a final seam comprised of five metal thicknesses, like in Figure 32 below. You can further break this down by examining the results of both the first and second operation seaming rolls. The first die has a wider roll that creates the initial loose fold. This operation puts the hooks in place but does not seal it. The second die is narrower, pressing the seam into itself and actually sealing the can.

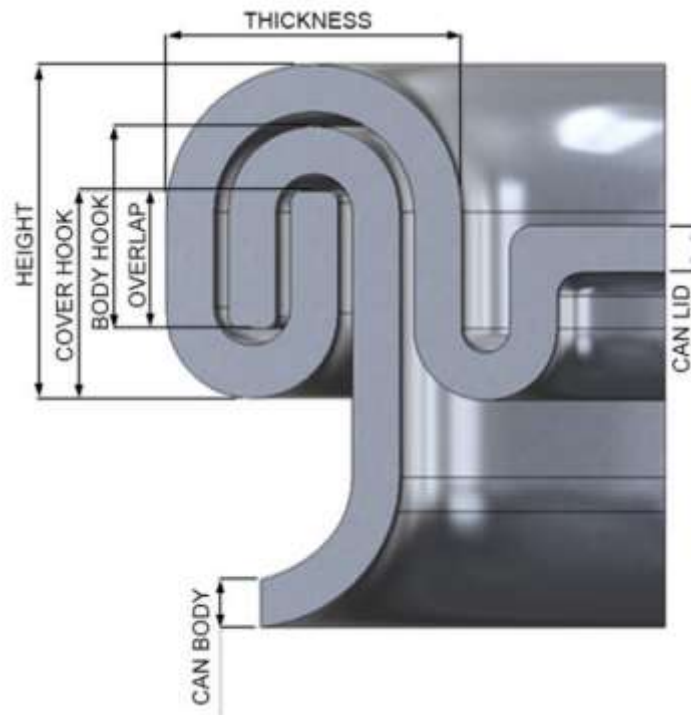

Figure 32 Visualization of a double seam in 3D

E.1 Can Seam Evaluation Training Videos

There are three detailed Can Seam Evaluation training videos available on our website which supplement the instruction in the following several pages: www.cask.com/service-support/seam-evaluation-videos/



E.2 Manual Seam Evaluation Process

Full can seam tear down should be done prior to production every day. Can seam height and width should be checked frequently (once every three to five minutes) throughout production. Production should be stopped if there is a change of more than 2/1000 on either dimension.

A full seam tear down should be performed to determine the cause of the change and the adjustments required. The procedure for checking the quality of your seams is called a “Can Seam Tear Down”. This enables you to make various measurements as outlined in this Section E.

E.3 Reading a Seam Micrometer

Before commencing a Can Seam Tear Down, you will need to be conversant in reading a seam micrometer.

Reading a micrometer of any kind is not as hard as some may think. If you can simply add and subtract, you can read a Micrometer. Below are a few simple pointers to get you started.

- Each “Tick” Thimble Sleeve is equal to 0.025” (25 Thousandths’ of an inch) therefore $0.025” \times 4 \text{ Ticks} = 0.100”$ and so on.
- Each “Tick” on the Thimble is equal to 0.001” (1 Thousandth of an inch) therefore on complete revolution from 0 back to 0 is equal to 0.025”.

Example #1

Looking at the photo below (Figure 33) note the Micrometer reads a total of 19 visible “Ticks” on the inside shaft. $19 \times 0.025 = 0.475”$. To make it simpler for the reader of the Micrometer the “Ticks” at every 0.100” are labelled in sequence 1-2-3-4-5-6 ... (1=0.100”, 2=0.200” so on). Figure 33 displays “4” = 0.400” + 3 “Ticks” = 0.075” to total 0.475”.



Figure 33 Seam Micrometer 0 – 1”, Example #1

Example #2

The following example (Figure 34) reads 10 “Ticks” each “Tick on the Thimble Sleeve is worth 0.025” therefore the Micrometer reads 0.250”. Simply explained “2” = 0.200” + 2 “Ticks” (0.025”) = 0.050” for a Total of 0.250”.



Figure 34 Seam Micrometer 0 – 1”, Example #2

Example #3

Notice in this example (Figure 35) the “0” is not Mated with the Thimble Sleeve (page 51) the “2” on the Thimble is in line with the Thimble Sleeve. We know from the previous example (Figure 34) that when the Thimble was at “0” the total was 0.250” as it is here, but ... The “2” (.002) is in line with the Thimble Sleeve so we need to add that to the 0.250” (0.250” + 0.002”) = 0.252”. If the “24” on the Thimble was in Line with the Thimble Sleeve we would take the read of above 0.250” and add the in line “24” (0.024”) = 0.274” overall.



Figure 35 Seam Micrometer 0 – 1”, Example #3

E.4 Seam Measurement

Seams should be checked on a regular basis in order to ensure the quality of your product. The procedure for checking the quality of your seams is to tear them apart and make various measurements as outlined below.

For this process you will require a couple of basic tools included with your equipment.

- A pair of side cutters strong enough to go through the aluminum of the can.
- A micrometer to make the very fine measurements required.

Refer to your Can Seam Specifications sheet (Table 10 Can Seam Specifications on Page 42) for the tolerances allowed when making these measurements.

E.4.1 Visual Evaluation

Before taking any measurements of the can, you can start the evaluation process by simply taking a look at the seam. You should see a nice, smooth, consistent rolled seam. There should be no damage to the body or cover of the can; this includes any warping or impact points, and fractures of the seam itself.

E.4.2 Seam Height

If the can passes a basic visual inspection and there are no obvious problems, you can move on to more precise measurements with your can seam micrometer. It is best to check the seam height and width before opening or cutting the can. For best results use a can seam micrometer for measuring seam width. It's design enables you to get consistent measurements. Using your micrometer measure the distance from the bottom to the top of the seam at various points around the can. The seam height should be relatively consistent, although some slight variances are to be expected.

Refer to Table 10 Can Seam Specifications on Page 42 for Seam Specs.

Note: to properly measure seam width place your finger on the micrometer as you tighten the thimble sleeve. Thimble sleeve must be tightened to just a sufficient degree (and no more) that when you remove your finger (see Figure 36) the micrometer does not move or sag.





Figure 36 Proper Seam Micrometer usage

E.4.3 Can Tear Down

After measuring the external seam height, start by opening and emptying a can that has been filled and seamed. Then use a pair of side cutters or nippers to cut a small section of the seam off of the can from the lip.

Then using a pair of needle nosed pliers, or some other similar tool pull the body hook away from the cover hook and unfold the cover hook from itself in order to be able to see it.

Refer to Page 35 of the Darex “Evaluating and Controlling Double Seams Manual” that you received with your system.

This video also shows the process of a [Manual Can Teardown](#).



Body Cover and Hooks

Now that you have taken the seam apart you can measure the cover and body hooks using the micrometer.

E.5 Seam Troubleshooting

After evaluating your seam height, body and cover hooks you might find that your measurements are not within the specified tolerances. If this is the case you need to make some changes to your seaming operations.

This could include the spacing of the dies, the speed at which they come into the can, or the height of the lift table. You can refer to the troubleshooting guide below in Table 9 to diagnose what is the cause of your problem and the adjustment required to fix it.

Seam Issue	Resolution
Body/Cover Damage	<ul style="list-style-type: none"> • Dies are impacting the can and moving into the chuck too fast • Dies are set too close to the chuck
Long Seam Height	<ul style="list-style-type: none"> • Die #1 set too far from the chuck • Die #2 set too close to the chuck
Short Body Hook	<ul style="list-style-type: none"> • Lift table set too low • Die #1 set too close to the chuck • Die #2 set too far from the chuck
Long Body Hook	<ul style="list-style-type: none"> • Lift table set too high • Die #1 set too far from the chuck
Short Cover Hook	<ul style="list-style-type: none"> • Lift table set too high • Die #1 set too far from the chuck
Long Cover Hook	<ul style="list-style-type: none"> • Die #1 set too close to the chuck.

Table 9 Common seam issues and problem resolution

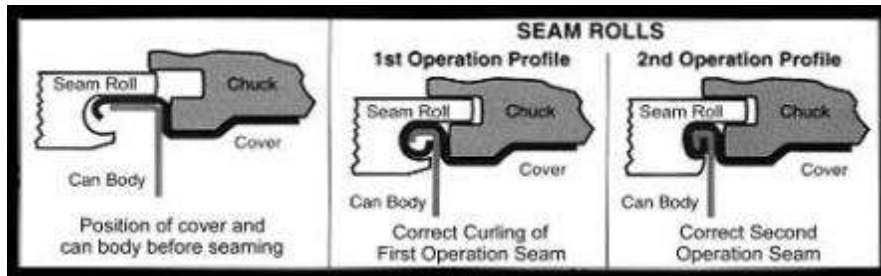

Figure 37 Seam roll process: first and second operation seams

E.6 Seam Specifications

Ball Can Seam Specifications

These specifications will vary depending on the kind of can 'end' and the particular format of can being used. Check with Ball to be sure you have the right seam specifications for your can and end format. For the typical 12oz (355mL), 16oz (473mL) and 500 ml Ball cans however the following Setup Parameters generally apply.

Parameter	Dimension ± Tolerance
First Operation Seam thickness	0.076" ± 0.002"
Second Operation Seam thickness	0.044" ± 0.002"
Seam Height	0.098" ± 0.002"
Cover Hook	0.060" ± 0.005"
Body Hook	0.065" ± 0.005"

Table 10 Can Seam Specifications

Note: the above dimensions are standard for 12oz (355mL), 16oz (473mL) and 500 ml Ball cans; however, if you are using another format, can size or manufacturer, please refer to the manufacturer's specification sheet for proper values.

Section F. Can Seamer

The process of double seaming an aluminum can is broken down into the following steps:

1. Once the can is placed on the lift table, the lift table then raises the can onto the chuck which will force the lid down into position on the can body and spin the can.
2. Once spinning, both dies will be pushed into contact with the can one after the other to create the seam.
3. The first seam roll ("First Op" or First Operation) curls the cover around and underneath the can body 'flange'.
4. The second seam roll ("Second Op" or Second Operation) compresses the seam creating a tight seal.
5. Once both seaming operations are complete, the lift table will drop, bringing the can back down.

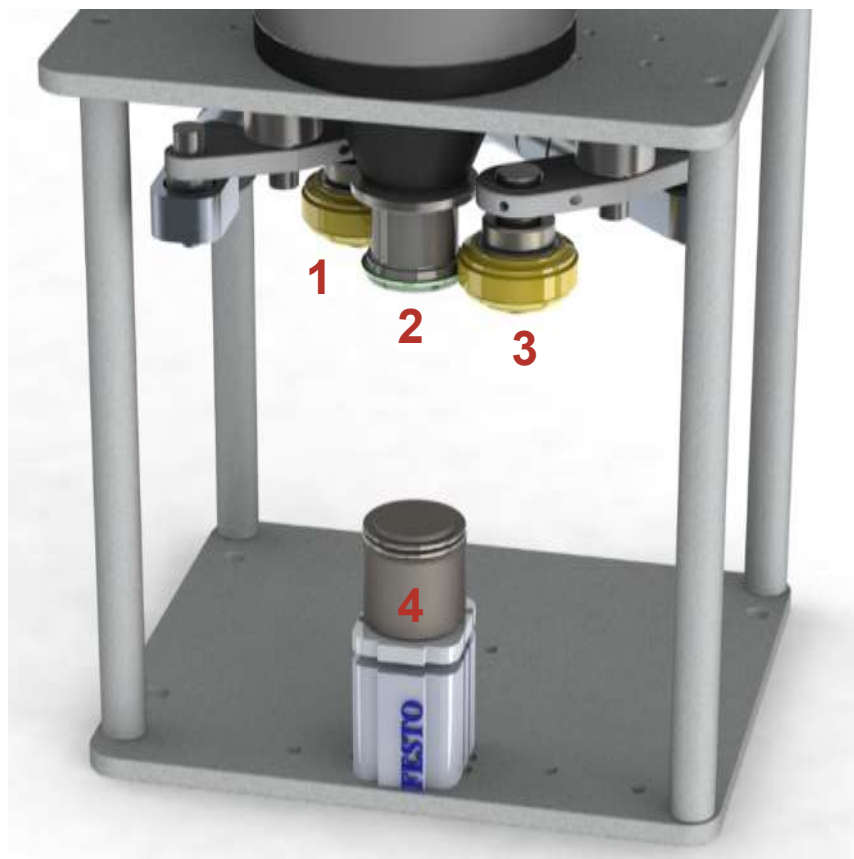

1. Die #1
2. Chuck
3. Die #2
4. Lift Table

Figure 38 Can seaming station

F.1 Seamer Adjustment & Troubleshooting

Good seams start with:

- The proper base plate pressure – see F.1.3 Can Table Height on Page 46.
- The proper first operation seam roll thickness (generally $0.076'' \pm 0.002''$).
 - This dimension is for standard Ball 12 and 16oz, 355 and 473 ml. If you are using any other can format, size or manufacturer, please refer to manufacturer for proper specifications.
- If this dimension is not in range, the cover and body hooks will be out of spec so always adjust this dimension first.
- The following Figure 39 identifies all the locations required to adjust and fine tuning the seaming process.

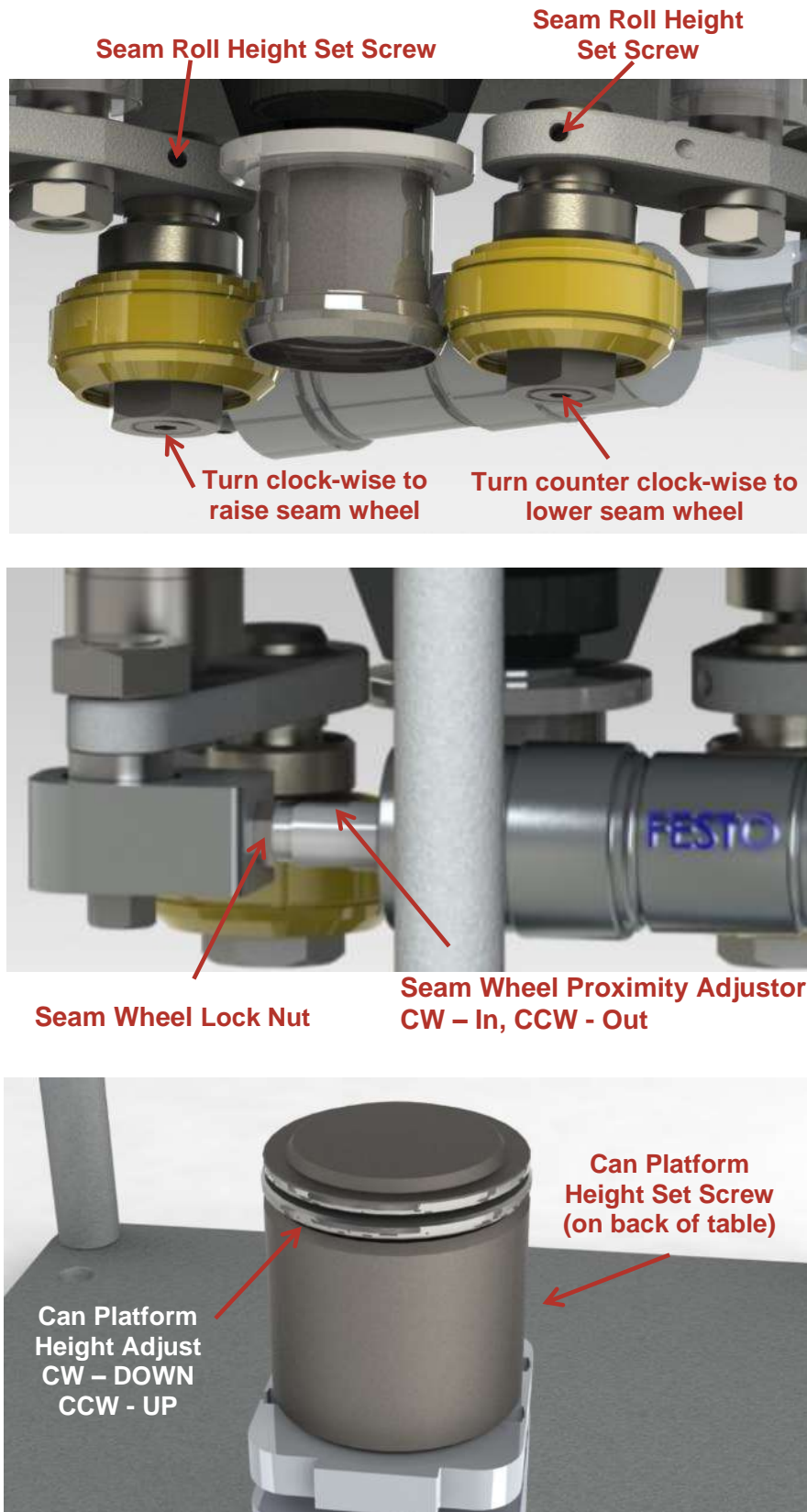

Figure 39 Can Seamer Adjustments

To ensure that the seam stays within specifications the following adjustments can be made.

F.1.1 Seaming Wheel Proximity Adjustment

When the cylinder arm that pushes the Seaming Roll to the Chuck is fully extended the Seaming Wheel reaches it's closest position to the Chuck. This position can be altered (moved closer to or further away from the chuck) by making the Seaming Wheel Proximity Adjustment.

- Set the unit into manual mode.
- To adjust the proximity of Die No. 1 (First Operation Seam Roll) first move this die into the chuck by turning the selector switch for Die No. 1 on. (If the die does not move be sure that your E-stop buttons are not engaged and that your air is on). Locate the set bolt nut. For this adjustment it is located on the block that the piston, which controls the movement of Die number one, is threaded into. This set nut must be loosened (2 or 3 full turns).
- Once loosened, the piston can now be rotated with a 1/2" wrench.
- Rotating the piston on the First Op Seaming Roll in a clockwise direction will move the seaming wheel CLOSER to the chuck. Observe the gap between the seaming wheel and the chuck as you turn the piston.
- Once the gap has been adjusted, retighten the set bolt.

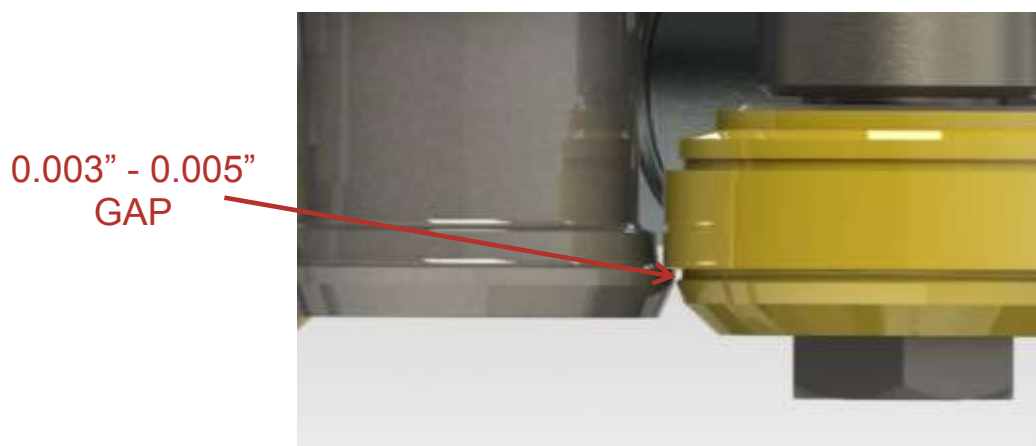

Figure 40 Seaming Wheel Proximity

F.1.2 Seaming Wheel Height Adjustment

The height of each seaming wheel relative to the chuck can be adjusted as described below (refer to Figure 41).

- Set the unit into manual mode.
- Loosen the set bolt (Figure 41 Photo A) which is located on the arm directly above the seaming wheel.
- Grab the nut at the base of the seaming wheel (or use an Allen key as shown in Figure 41 Photo B) to turn the seaming wheel. Clock-wise moves the wheel up. Counter clock-wise moves it down.
- Observe the gap between the top surface of the chuck and the overhanging section of the seaming wheel. There should be approximately one paper width of gap apparent on the first operation seaming wheel (0.003"-0.005"). Approximately 1.5 times that for the second operation seaming wheel. (Figure 41 Photo C)
- Once the seam wheel height has been adjusted, retighten the set bolt.

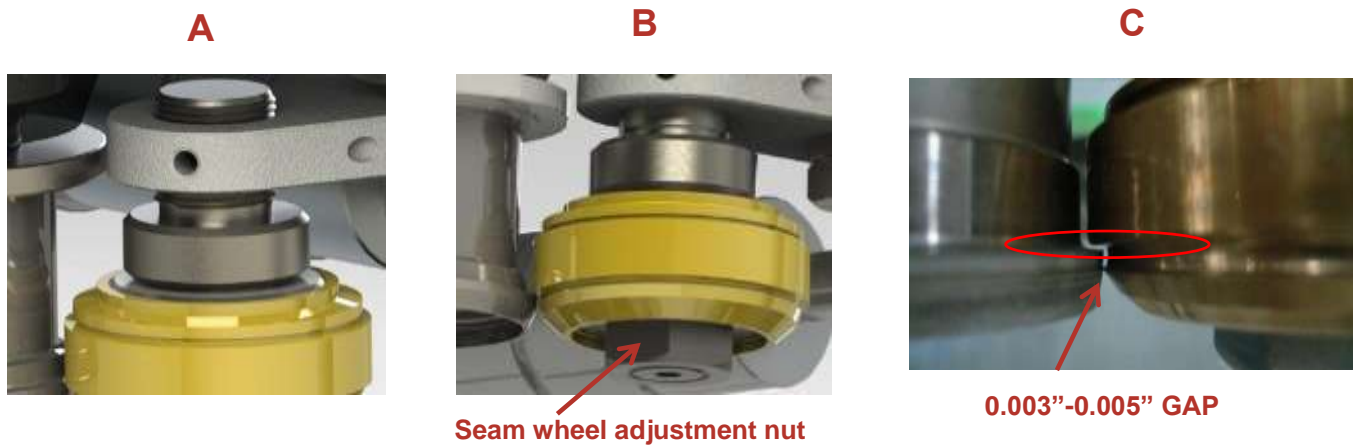

Figure 41 Seaming Wheel Height Adjustment

F.1.3 Can Table Height Adjustment

The can platform must be set at a height that ensures adequate tension – or “base-plate pressure” - on the can so as to ensure the can does not slip on the platform during the seaming cycle. This base plate pressure must not be so high however that it crushes or wrinkles the can during the cycle.

When the can platform is in the 'up' position the can should be firmly locked in place against the chuck. To regulate the amount of pressure exerted on the can (from top to bottom) during the seaming cycle the height of the can platform can be adjusted.

Steps to set up or adjust the can seam height:

- You can access the can seam height set screw in front of the can platform.
- With the unit in manual mode, actuate the can lift button so that the can platform is extended.
- Loosen the can seam height set bolt 2 or 3 turns.
- Grasp the middle section indicated above by the red arrow in Figure 42 (not the top section on which the can rests).
- Turn clock-wise to increase the height, counter clock-wise to lower it.
- For initial set up, raise the platform until there is tension against the can.
- Drop the platform (with the selector button) and remove the can.
- Raise the platform again and continue increasing the height of the platform for a further half to $\frac{3}{4}$ turn.
- Tighten the set screw.



Figure 42 Can Table Height Adjustment

IMPORTANT: If at any time during operation you see a can ‘slip’ or hesitate during the seaming process (instead of spinning continuously during the seaming cycle) the can platform height must be increased.

F.1.3.1 Can Table Pressure - Test for Too Low

- Place a full, seamed can of beer in place.
- Raise the table.



- Grasp the can in one hand and the base plate table in the other and try to turn these in opposite directions.
- If you can turn them and feel the can slipping on the base plate, there is probably too little pressure.
- Try raising the platform another quarter turn and try again.
- Once properly adjusted be sure to retighten the set bolt.

F.1.3.2 Can Table Pressure - Test for Too High

- Place an empty can on the platform, lid in place.
- Raise the platform.
- Press against the can wall with your finger.
- A small amount of pressure should cause the can to indent and remain indented after you move your finger.
- If you lower the can and the dent pops out, you have a good can table pressure. If the dent remains in the can when the table is lowered, you have too much can pressure and should adjust the can table down a quarter turn and repeat.

F.1.4 Speed of Cylinder Motion

In addition to the above adjustments, the speed at which each of the seaming wheels moves into place during the approximately 2 second long seaming cycle can also affect the final seam specifications. This speed is controlled by the flow controls on air valves which control the flow of air to the air cylinders that move the seaming wheels and the can platform. Refer to Section D.8.2.1 Air Cylinder Speed Adjustment on Page 31 for details on how to adjust the air cylinders.

F.2 Seamer Troubleshooting

Testing the First Operation Seam Roll Thickness

- A test seam must be done with water or beer filled can in manual mode.
- Place can on table and push “Test Die 1”.
- Check the thickness of this seam as shown (Figure 36 Proper Seam Micrometer usage on Page 41).
 - **Note** For most accurate measurements, the use of a can seam micrometer is recommended.
- If the seam thickness is too high, the seam roll must be moved closer to the chuck (F.1.1 Seaming Wheel Proximity Adjustment on Page 45). If too tight (small) it must be moved away from the chuck.
- Verify also that the first operation seam height (Figure 36 on Page 41) is within 0.003”-0.005” of the first op seam thickness. If it is too short, the seam roll height must be raised.

F.3 Bearing Replacement

Changing bearings on the Cask Canning System is relatively simple; however, it can be frustrating if these simple steps below in Figure 43 are not followed in order of operation.



SPINDLE HOUSING

CAN TABLE

Collapsed View



IMPORTANT: WHEN INSTALLING BEARINGS ON SHAFT ALWAYS PRESS ON THE INNER RACE. WHEN INSTALLING IN HOUSING ALWAYS PRESS ON OUTER RACE.

Collapsed View



Exploded View



1. Spindle
2. Spindle Housing, place over top of spindle
3. Bearing slide onto Spindle and into Spindle Housing
4. Spindle Housing Bearing Spacer
5. Spindle Bearing Spacer
6. Bearing slide onto Spindle and into Spindle Housing
7. Bearing Retainer Ring & 4 Bolts
8. Lock washer & Spanner Nut

1. Can table top
2. Slide Bearing onto Shaft
3. Install Snap Ring Retainer into Groove
4. Slide Second Bearing onto Shaft
5. Insert bearings and Can Table Top into Can Table Top Housing (External Threads)
6. Screw Table Top Housing into Mate (#6)



Exploded View



Figure 43 Spindle and Can Table Bearing Replacement schematic



Section G. Safety

Safety is always a concern in every facet of life. Always remember to use caution when operating any Machinery. Keep these simple steps in mind when operating Cask Brewing Systems Machinery.

- Always wear Safety Glasses when operating Machinery to prevent damage to your eyes.
- Wear the appropriate footwear for your application i.e. Steel Toed Safety Boots to prevent damage to your feet from possible falling debris.
- NEVER wear Gloves of any kind when operating Machinery. Moving parts can catch the gloves and pull you into the machine resulting in possible injury.
- There are many moving parts on Casks Machinery. Please use caution when operating any component, keep note that any moving part is a potential hazard.
- Compressed Air is used in many components of this Machine and while it is an optimal operating component, it does pose a threat. Compressed air if directed at the skin can enter the blood stream through the skin resulting in Air embolism. Please keep skin protected and out of the way of main stream compressed air.



Section H. Warranty Information

The warranty shall be limited to the following from the date of installation of the Canning System by a Cask Technician Representative at the customer's site

Item	Warranty Duration
Large and small coils	3 months
Motors	3 months
All bearings	3 months
All other equipment	1 year

Chuck and seam rolls: If the seams are improperly set and there is improper contact of the seam wheels to the chuck, the warranty for these items is void.

The warranty shall be limited to the supply of parts to replace components found to be defective, but shall not include freight and labour costs relative thereto.

Cask Brewing Systems Inc. shall not be liable for any claim of lost revenues, products or profit resulting from any defect which is the subject of a proper warranty claim.

If more than one Canning System shall be purchased by the Purchaser at one time, a warranty claimable defect found in one system shall not entitle the Purchaser to refuse payment or delivery or to claim a set-off in respect of the price of any other system or systems so purchased.

Since the Canning System is installed as a system, the Purchaser shall not add equipment of any other manufacture, except as may be suggested by the Vendor during the applicable warranty period. Breach of this condition by the Purchaser shall invalidate the Vendor's warranty.

Third party equipment warranty to be supplied by third party vendor.

Warranty is null and void if installation and training offered by Cask Brewing Systems Inc. is refused by Purchaser.



Section I. Company Information

Cask Brewing Systems Inc.
Bay 60, 5100-64 Ave SE
Calgary, Alberta, T2C 4V3
CANADA

Toll Free +1-800-661-8443
Direct +1 403-640-4677
Fax +1 403-640-4680
Email info@cask.com
Website www.cask.com



Technical Service & Support

Toll Free +1-800-661-8443 Option #4
Direct +1 403-640-4677 Option #4
support@cask.com

Parts Order

Toll Free +1-800-661-8443 Option #4
Direct +1 403-640-4677 Option #4
parts@cask.com



www.cask.com

