

**MULTISTAGE CONDENSING  
STEAM TURBINE GENERATOR SET**

DRESSER-RAND, Steam Turbine Division, proposes to furnish and deliver to the Purchaser, the Equipment described below FOB/Factories suitably prepared for domestic shipment.

One (1) DRESSER-RAND Steam Turbine/Generator Unit consisting of the following major components:

- One (1) 2500 KW, 6000 rpm, Multistage, Condensing Steam Turbine
- One (1) 2500 KW, 0.85 PF, 3 Phase, 60 Hertz, 4,160 Volts, 1800 RPM, Electric Generator and Exciter.
- One (1) Single Reduction Parallel Shaft Speed Reduction Gear with 1.3 Service Factor.
- One (1) Complete Lubrication System with Oil Reservoir Located in Baseplate.
- One (1) Electro-Pneumatic Control System.
- One (1) Local Turbine Gageboard.
- One (1) Baseplate Under Turbine, Gear, & Generator.
- One (1) High Speed Coupling & Guard for Connecting the Steam Turbine to the Reduction Gear.
- One (1) Low Speed Coupling & Guard for Connecting the Reduction Gear to the Generator.
- One (1) Generator Control & Switchgear Cubicle.
- One (1) Condenser & Accessories

# DRESSER-RAND

PROPOSAL NO. 5/BA24/100-00  
REFERENCE NO. \_\_\_\_\_

## PERFORMANCE DATA

	<u>Normal</u>	<u>Maximum</u>	<u>Minimum</u>
Steam Inlet Pressure (PSIG) @ Turbine Inlet	190	200	180
Steam Inlet Temperature (°FTT) @ Turbine Inlet	384	388	380
Exhaust Pressure ("HGA)	2.0	3.0	2.0
Rated Output (KW at GENERATOR TERMINALS)	890	2500	600
Throttle Flow Required (LBS/HR)	15,000	43,000	12,000
Exhaust Enthalpy (BTU)	995	986	975
Speed (RPM)	6000/1800	6000/1800	6000/1800

***GUARANTEE POINT = NORMAL CONDITION***

## TECHNICAL DATA

Steam Inlet Flange	6" - 600 lbs./RF - ASA
Steam Exhaust Flange	30" - 125 lbs./FF - ASA

Serial No.: D-4060

Turbine Frame: S-6

Gear Frame: Nuttall SD16-6L

Generator: Ideal Electric Generator

Turbine Rating: 3352 HP / 2500 KW at 6000 RPM

Rotation Viewed From Governor End of Turbine: Clockwise

Casing Material: Cast Steel Steam End / Cast Iron Exhaust End

Number of Turbine Stages: 1 Curtis and 6 Rateau

Shaft Packing, Labyrinth Rings: 6 at Steam End  
3 at Exhaust End  
1 in each Diaphragm between Stages

Sentinel Valve sounds a warning at 5 psig

Exhaust Relief Valve starts opening at 6 psig;  
opens fully at 10 psig to pass 49172 LB\HR of steam

Oil: SAE 20

Bearing Lubrication: Pressured Lubed At 20 psig

	<u>Flow</u>	<u>Pressure</u>	<u>Driver</u>
Main Oil Pump:	38 GPM	40 psig	Supplied By Nuttall Gear Motor
Auxiliary Oil Pump:	38 GPM	40 psig	

Cooling Water Required

For Oil Cooler: 50 GPM at 85°F

For Gland Condenser: 22.2 GPM at 85°F

## SCOPE OF SUPPLY

### Turbine

One (1) Multistage, Frame "S", Single Valve, Steam Turbine, Rated for Continuous Duty up to 700 PSIG - 750°FTT, and Including the Following Accessories:

- 6" Cast Steel Inlet
- 30" Cast Iron Exhaust (UP or DOWN)
- 6" Trip & Throttle Valve w/Stainless Steel Removable Strainer, & Start-Up Strainer
- Hand Valves for Part Load Economy
- Tilt Pad Radial Bearings
- Tilt Pad Thrust Bearing
- Electronic Governor (Woodward 505 or Equal) w/Pneumatic Actuator & Dual Pickups
- Labyrinth End Glands & Interstage Glands Arranged for Automatic Gland Sealing
- Gland Condenser (Shipped Loose for Field Mounting)
- Insulation on Turbine Case & Steam Chest w/Sheet Metal Jacket
- Case Drains Piped & Valved to Edge of Base
- Performance Curves -Flow vs. Output
- Lateral Critical Speed Analysis - Dresser-Rand Standard
- Solenoid Trip Device
- Low Oil Pressure Trip Valve
- Trip Limit Switch
- Separate Gageboard - Floor Mounted
- Customer Test Points:
  - Case Hydro Test - Certified
  - Final Rotor Balance - Certified
  - One (1) Hour No-Load Run Test - Witnessed
- NEMA 1 - Electrical Equipment
- All Electrical Wired to Oversized Junction Boxes
- Turning Gear - AC Motor

### Gear

One (1) Lufkin or Nuttall Speed Decreasing Gear, Single Reduction, with:

- Ratio - 6000/1800
- AGMA Service Factor at 2500 KW - 1.3
- Fabricated or Cast Iron Housing
- Shaft Driven Main Oil Pump to Provide Lube Oil to Turbine, Gear, & Generator
- Sleeve Radial Bearings
- Thrust Collar

## SCOPE OF SUPPLY

Fabricated Steel Baseplate - Under Turbine, Gear, and Generator

High and Low Speed Couplings with Guards - Spacer Type

### Lubrication System

One (1) Lubrication System for Turbine, Gear, and Generator including:

- Carbon Steel Reservoir Built into Baseplate
- Open Drip-Proof Motor Driven Auxiliary Oil Pumps - AC & DC (MOP Mounted on Gear)
- Dual Filters w/25 Micron Filtration Design
- Dual Coolers - 3/8" Tubes, 85°F Cooling Water Design
- Three (3) Way Transfer Valve
- Pressure Gages for Filter Inlet & Discharge
- Air Vent
- Lube Oil Control Valve
- Auxiliary Oil Pump Start Pressure Switch
- Auxiliary Oil Pump Bypass Relief Valve
- Low Oil Pressure Switch
- High Oil Temperature Switch
- Dial Thermometers - In/Out of Cooler
- Flanged & Welded Carbon Steel Piping Throughout
- Sight Flow Indicators in Each Bearing Drain Line (5 Total)
- Reservoir Heater
- Differential Pressure Switch for Filters
- Oil Level Switch
- Customer Connection for Oil Separation System

### Generator

One (1) Synchronous Generator (Ideal Model SAB or Equal) - Brushless Design, Rated 2941 KVA, 2500 KW, at 0.85 Power Factor, 1800 RPM, 3 Phase/60 HZ/4160 Volt, WYE Connected, 6 Leads, 105°C Rise By Resistance Above a 40°C Ambient, Class F Insulation, Continuous Duty Design including:

Electrical Features:

- Damper Windings
- Insulation System to be VPI-Complete Stator
- Field Suitable for Excitation from Brushless Exciter
- Capable of Operating at Rated KVA & Rated Temperature Rise at Altitudes of 3300 Feet Above Sea Level

## SCOPE OF SUPPLY

### Generator

#### Electrical Features (Continued)

- Efficiency Guaranteed at Loads:

4/4	-	96.2
3/4	-	96.1
1/2	-	95.4
- Six (6) Leads for Differential Protection
- Short Circuit Ratio Not Less Than 0.6

#### Mechanical Features

- Two (2) Sleeve Bearings, Bracket Mounted, Suitable for Forced Feed Lubrication from System Furnished by Customer. Ideal will provide Oil In & Oil Out Connections at Bearing Housings Only. No piping is included.
- One (1) Bearing is to be Insulated to Prevent Shaft Currents
- Mechanical Balance per NEMA Standard
- Open Drip-Proof Enclosure with Filters
- Unit to be Capable of 125% Overspeed without Mechanical Injury

#### Accessories

- Bearing Temperature Detectors - One (1) per Bearing, RTD Type, 120 Ohm Nickle
- Two (2) Grounding Pads on Frame to be Located Diagonally Opposite of Each Other
- Space Heaters
- Six (6) Stator Temperature Detectors, RTD Type, 120 Ohm Copper
- Main Terminal Box Including:
  - Lightning Arrestors
  - Surge Capacitor
  - Oversized to Accomodate Stress Cones Furnished by Others
  - 3 Cts for Differential Protection
  - 3 Cts for Metering
- Brushless Exciter
- Permanent Magnet Alternators (PMA)
- One (1) RTD in Inlet Air Path
- Furnish & Mount B-N Vibration Equipment - Two (2) Probes per Bearing

## SCOPE OF SUPPLY

### Generator Auxiliary Equipment

One (1) Static Voltage Regulator System Including:

- Two (2) Static Voltage Regulators,  $\pm 1/2\%$  with Single Phase Sensing, Parallel Circuit
- Dual Voltage Adjusting Rheostat - Single Motor Operated
- Underfrequency Protection
- Var/PF Controller
- Manual Voltage Control Module with Selector Switch
- Exciter Diode Failure Monitor
- Minimum/Maximum Excitation Limiter

One (1) Neutral Grounding Resistor Rated 400 AMPS, 10 Seconds, 2400 Volt L/N with Safety Enclosure and CT.

# IDEAL ELECTRIC CO.

250 EAST FIRST STREET • MANFIELD, OHIO 44868 • USA  
 TELEPHONE (419) 522-3511 • FAX (419) 522-3558

## SYNCHRONOUS GENERATOR DATA

105 °C RISE      KW      2500      KVA      2941      P.F.      0.85  
 VOLTS      4160      AMPS      408      RPM      1800

### REACTANCES

PER UNIT ON      2941 kVA BASE

Direct Axis Synchronous	(Unsaturated)	Xd	1.729
Direct Axis Transient	(Rated Voltage)	X'd	0.239
Direct Axis Subtransient	(Rated Voltage)	X''d	0.167
Quadrature Axis Synchronous	(Unsaturated)	Xq	0.899
Quadrature Axis Subtransient	(Rated Voltage)	X''q	0.163
Negative Sequence	(Rated Voltage)	X2	0.170
Zero Sequence	(Rated Voltage)	Xo	0.065
Short Circuit Ratio		SCR	0.750

### TIME CONSTANTS

Direct Axis Open Circuit Transient	T'do	3.710 Sec.
Direct Axis Short Circuit Transient	T'd	0.512 Sec.
Direct Axis Short Circuit Subtransient	T''d	0.030 Sec.
Short Circuit Armature	Ta	0.041 Sec.

### RESISTANCES

Armature (per phase at 25°C)	0.04495 Ohms
Field (at 25°C)	0.484 Ohms
Rotor Inertia	2200 Lb-Ft <sup>2</sup>

### EFFICIENCY

Load	Eff. at 0.85 P.F.
4/4	96.2%
3/4	96.1%
1/2	95.4%

JATE 10/09/95

Ref: 2112018



**SCOPE OF SUPPLY****Generator Control & Switchgear Cubicle**

One (1) Generator Control & Switchgear Cubicle, 2500 KW, 0.85 PF, 4160V, 3P, 4W, 60 Hz, ANSC 37, Indoor Construction with Approximate Dimensions of 94"H, 72"W, 90"D to include:

- Generator CB, Vacuum, 4160V, 3P, 1200A, EO, DO, 350MVA
- Surge Protection Arrestor, 4160V, 3P
- AC Instrumentation: Electronic Multimeter to Include AM, VM, FM, KW, KVAR, KWH, KVARH, PF, 1% Class - Utility Grade
- RTD Monitor Relay - Two (2) Channel with Temperature Meter & Channel Selector Switch
- Control & Synchronizing Panel to include:
  - Annunciator, 12 Point, with Ringback Control Logic, Reset, PB, Silence PB, Lamp Test PB, & Horn
  - Sync Scope
  - Sync Lights
  - Sync Switch
  - Voltage Adjust Potentiometer
  - Speed Adjust Up/Down Switch
  - Mode Control Switches
- Device 15V - Electronic Synchronizer with 5% Voltage Match, SPMA
- Device 90PF - VAR-Power Factor Controller, Type SCP250
- Device 51V - Phase Overcurrent Relay with Voltage Restraint
- Device 51N - Ground Overcurrent Relay
- Device 87 - Phase Differential Current Relay with Six (6) Cts
- Device 86 - Lockout Relay
- Device 32 - Reverse Power Relay
- Device 40 - Reverse VAR, Loss of Excitation Relay
- Device 46 - Negative Sequence Current Relay, 3P
- Circuit Breaker Control Switch with R/G Indicating Lights
- Two (2) Sets of Potential Transformers with Fusing
- Three (3) Sets of Current Transformers with Shorting Blocks
- Mount/Wire Speed Governor Equipment Furnished by Customer
- Mount/Wire Voltage Regulating Equipment Furnished by Customer
- Transition Section for Connection to Bus Bar
- Station Battery & Charger, 48VDC, Powered from Separate 120 Volt Source Provided by Others
- Space Heater & Humistat Control Powered from Separate 120 Volt Source Provided by Others

**Condenser**

One (1) Graham or Equal Condenser System in accordance with the Attached Seven (7) Vendor Information Sheets.



Customer : Dresser-Rand  
 Customer Ref: RRF Expansion  
 Location : Harrisonburg, VA  
 Item : T/G

Ref.No. : 81BAT95  
 Date : 10/09/95  
 Engineer: KGG  
 Page : 1

#### SCOPE OF SUPPLY

Vendors and model numbers are listed to illustrate construction features. Graham reserves the right to substitute equipment of an equal type and quality by other vendors. Any items omitted from this scope of supply list are excluded from this quotation at this time and will not be furnished.

**SURFACE CONDENSER TUBED IN SHOP**  
 (1 ) Model 38 51 / 17.00 TALTD

Drawing A81BAT95-1

**STEAM JET AIR REMOVAL PACKAGE**  
 (1 ) Model 1-32-088-2

Drawing A81BAT95-2

**LIQUID RING VACUUM PUMP AIR REMOVAL PACKAGE**  
 (1 ) Model 1PV62160/12

Drawing A81BAT95-3

**ATMOSPHERIC RELIEF VALVE**  
 (1 ) Viking 24" Vertical Carbon Steel

**HOGGING EJECTOR**  
 (1 ) Graham, 2H Cast Iron  
 Silencer, Maxim, Model 2" FP Crb.stl, Internals, Flg./w F.G. Pack

**HOTWELL GAUGE GLASS**  
 (1 ) Consolidated #20-207, Bronze tubular

**VACUUM GAUGE(S)**  
 (1 ) U.S. Gauge #1981, 4-1/2", 316SS tube, PET case, 316SS Lower stem

**PRESSURE GAUGE(S)**  
 (1 ) U.S. Gauge #1981, 4-1/2", 316SS tube, PET case, 316SS Lower stem  
 (1 ) Pigtail Syphon, U.S. Gauge, 517H 1/2" Carbon steel

**TEMPERATURE INDICATORS**  
 (2 ) U.S. Gauge 65300674 5" Dial Every angle 304SS case  
 (2 ) U.S. Gauge Thermowell No. 3/4"-2605-U4.5-304SS, 3/4" NPT, 304SS

**AIR LEAKAGE METER**  
 (1 ) Graham, Calibrated Orifice with gauge, 0 - 40 PPH

**INTERCONDENSER CONDENSATE TRAP**  
 (1 ) Sarco ASTM A126, Type-FA30, 1"

**AFTERCONDENSER CONDENSATE TRAP**  
 (1 ) Sarco ASTM A126, Type-FA30, 1"



**SURFACE CONDENSER SPECIFICATIONS**

Customer : Dresser-Rand	Ref.No. : 81BAT95
Cust.Ref. : RRF Expansion	Date : 10/09/95
Location : Harrisonburg, VA	Item : Peak design
Quantity : one	Engineer : KGG/BAT81

**PERFORMANCE**

Absolute Pressure @ Steam Inlet (in.HgA).....	3.00
Steam Condensed (lb./hr.).....	43000.
Heat Rejected (Btu/hr.).....	38829000.
Circulating Water (gpm).....	3883.
Water Inlet / Outlet (deg.F).....	85.00 / 105.00
Water Pressure Loss : (ft.Water / psi).....	15.0 / 6.5
Percent Clean.....	85.
Tube Velocity (fps).....	7.63

**DESIGN**

Surface Area (sq.ft.) Total / Effective.....	MODEL : 38 51 / 17.00 TALTD	3271. / 3208.
Number of Water Passes.....		2.
Number of Tubes.....		980.
Outside Tube Diameter (in.) - BWG.....		0.7500 - 18 AW
Total Tube Length (ft.).....		17.00
Design / Test Pressure (psig) :	Shell.....FV&	15.0 / Flooded
	Tubes.....	125.0 / 187.5
Design Temperature (deg.F) :	Shell.....	250.0
	Tubes.....	125.0
Hotwell : cylindrical ...supply (gal.).....		220.
Steam Inlet Diameter (in.) (FF).....		40.
Water Connections (in.).....		2. - 20.
Condensate Outlet (in.).....		1. - 6.0

**MATERIALS**

Shell	(SA-516-70)	Carbon Steel
Water Boxes	(SA-516-70)	Carbon Steel
Water Box Covers	(SA-516-70)	Carbon Steel
Baffles	(SA-516-70)	Carbon Steel
Tube Support Plates	(SA-36)	Carbon Steel
Tubes	(SB-111-443)	Admiralty
Tube Sheets	(SB-171-464)	Naval Rolled Brass

Remarks : Design per HBI, Ninth Edition  
 Construction and Stamp per ASME Section VIII , Div. 1 , Tube Side Only  
 Steam Inlet Impingement Protection Included  
 Water Boxes and Covers to be Coal Tar Epoxy Coated  
 Ejector Package Mounted on the Main Condenser



Customer : Dresser-Rand  
 Customer Ref: RRF Expansion  
 Location : Harrisonburg, VA

Ref.No. : 81BAT95  
 Date : 10/09/95  
 Item :  
 Engineer: KGG

**STEAM JET EJECTOR PERFORMANCE:**

Pressure maintained (inches HgA)*.....	1.0
Total Fluid Evacuated (lbs/hr).....	43.2
Dry air evacuated (lbs/hr).....	13.5
Motive steam required per element (lbs/hr).....	195.0
Operating steam pressure (psig).....	175.0
Operating steam temperature (deg.F).....	377.0
Inter condenser cooling water temp. (deg.F).....	85.0
Inter condenser cooling water required (gpm).....	59.3
Cooling water pressure drop thru I/A condenser (psi)...	0.7
.....	
.....	
.....	

**STEAM JET EJECTOR DESIGN:**

Model designation.....	1-32-088-2/2H
Number of stages.....	TWO
Number of elements for parallel operation.....	ONE
Material of diffuser and suction chamber.....	SA-278-35
Material of steam nozzles.....	416SS
Type of inter and after condenser.....	IN-LINE
Material of inter and after condenser shell.....	SA-53-B
Tube sheets.....	SA-516-70
Tubes .....	0.7500 - 18 BWG AW SB-111-443
M.A.W.P/ Test Pressure (psig) :	Shell..... 20 / 30
Design Temperature (deg.F) :	Tubes..... 125 / 188
	Shell..... 250
	Tubes..... 125

**APPURTENANCES INCLUDED:**

Steam strainer.....	Included
Interconnecting steam piping.....	Included
Air leakage meter.....	Included
Priming ejector - Size.....	2H(7C)
Steam consumption (lbs/hr).....	375.0
Drainers or traps.....	Included
Design per HEI Construction of I/AC per ASME Sec. VIII Div I.....	
Isolation valve(s) at 1st stage discharge.....	Included
Isolation valve at hogger suction.....	Included
Suction Manifold .....	Included
Hogging Ejector silencer.....	Included
Motive steam stop valve for each jet.....	Included
.....	
.....	
Measured at condenser inlet.	



**LIQUID RING PUMP SPECIFICATION SHEET**

1 CUSTOMER: Dresser-Rand EG NO : 81BAT95  
 2 USER : Harrisonburg, VA JOB NO : \_\_\_\_\_  
 3 PLANT LOCATION : \_\_\_\_\_ CUST NO : \_\_\_\_\_  
 4 SERVICE OF UNIT: \_\_\_\_\_ DATE : 10/09/95  
 Engineer: KGG

**PERFORMANCE REQUIREMENTS**

5 GAS HANDLED: AIR/WATER VAPOR  
 6 SUCTION PRESSURE: 50.0 mmHgA SUCTION TEMPERATURE: 93.6 F  
 7 SEALANT FLUID: WATER SEALANT TEMPERATURE: 80.0 F  
 8 COOLING WATER TEMP: N.A. F SOURCE: \_\_\_\_\_  
 9 ELECTRIC SUPPLY: VOLTS: 230/460 PHASE: 3 CYCLE: 60

**PUMP SELECTION**

10 MODEL NO: 1PV62160/12  
 11 STAGES: two SHAFT SEAL: packing glands  
 12 MAT'L OF CONSTR: cast iron case, ductile iron rotors, SS shaft  
 13 SPEED: 1750 RPM DISCHARGE PRESS: 14.7 psia  
 14 CAPACITY: 330.7 ACFM AT SUCTION PRESSURE OF: 50.0 mmHgA  
 15 HORSEPOWER-AT OPERATING POINT: 26.4 bhp MAXIMUM: \_\_\_\_\_  
 16 SEAL LIQUID: WATER QUANTITY: 20.0 GPM TEMP: 80.0 F  
 17 FLOW: once through

**MOTOR DETAILS**

18 HORSEPOWER: 40 hp SPEED: 1750 rpm  
 19 ELECTRIC SUPPLY: VOLTS: 230/460 PHASE: 3 CYCLE: 60  
 20 ENCLOSURE: ODP  
 21 MAKE: Reliance or Equal  
 22 SPECIAL FEATURES: \_\_\_\_\_

**OPTIONAL ACCESSORIES**

23 BASEPLATE: included for LRVP and motor only  
 24 COUPLING & GUARD: included, T.B. Woods or equal  
 25 DISCHARGE SEPARATOR: included, steel  
 26 SEAL WATER REGULATING VALVE: included, bronze  
 27 SEAL WATER PRESSURE GAUGE: included  
 28 SEAL WATER SOLENOID VALVE: included, brass  
 29 VACUUM GAUGE: included  
 30 VACUUM RELIEF VALVE: included, aluminum  
 31 SEAL WATER STRAINER: included, cast iron  
 32 SEAL WATER SHUTOFF VALVE: included, brass  
 33 INLET CHECK VALVE: included, bronze  
 34 RECIRCULATION PUMP: none  
 35 HEAT EXCHANGER: none  
 36 INTERCONNECTING PIPING: included  
 37 MANUAL DRAIN AND FILL VALVES: included  
 38 GAUGE GLASS: included Bronze 3/4" glass diam  
 39 COMMENTS: Performance tolerance per HEI.  
 40 \_\_\_\_\_  
 41 \_\_\_\_\_  
 42 \_\_\_\_\_  
 43 \_\_\_\_\_  
 44 \_\_\_\_\_

\*\*\* PRELIMINARY DRAWING NOT CERTIFIED FOR CONSTRUCTION \*\*\*

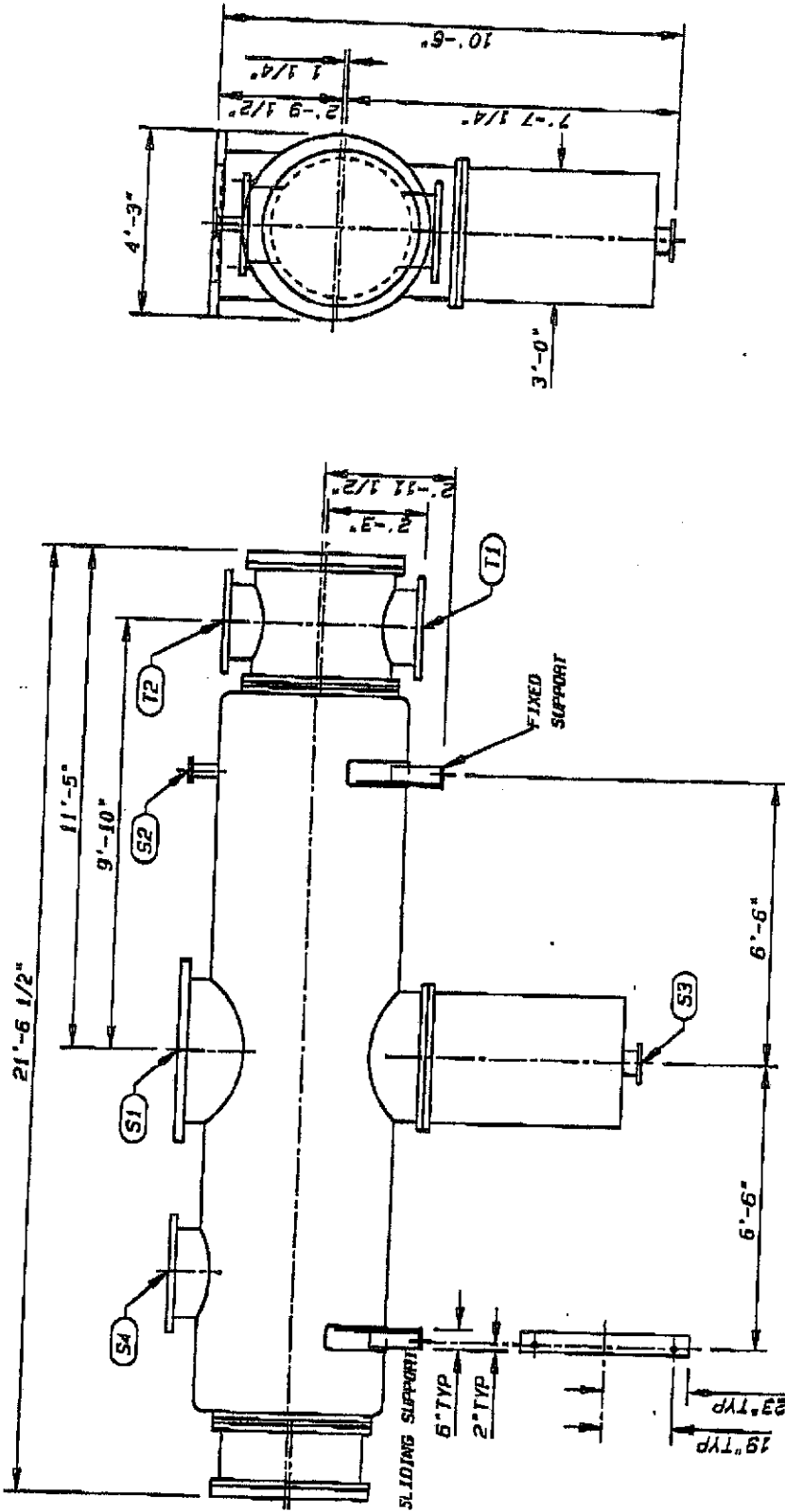

NOTE:  
 CONNECTION FLANGES ARE ANSI STANDARD DRILLING AND THICKNESS UNLESS OTHERWISE NOTED.  
 CUSTOMER TO SPECIFY COOLING WATER NOZZLE ARRANGEMENT.  
 STEAM INLET FLANGE THICKNESS PER PET.  
 SLIDING SUPPORT: (2) 1 1/8" x 1 1/2" SLOTTED HOLES.  
 FIXED SUPPORT: (2) 1-1/8" DIA. HOLES.

GRAHAM MANUFACTURING CO., INC.		20 FLORENCE AVE. BATAVIA N.Y.	
PRELIMINARY SURFACE CONDENSER DRAWING		SCALE	DATE
1/4" KGG	10/9/95	DWG. NO.	AB18AT95-1
REV.			
T1	20"	150# RF COOLING WATER INLET	Customer Dresser-Rand
T2	20"	150# RF COOLING WATER OUTLET	Customer REF. RRF Expansion
S1	40"	FF STEAM INLET	MODEL 3851/17.00TALTD
S2	3"	150# RF AIR OFF TAKE	M.A.W.P. TEST PRESS. 3851/17.00TALTD
S3	6"	150# RF CONDENSATE OUTLET	SHELL SIDE 15 PSIG 23 PSIG
S4	24"	150# RF RELIEF VALVE	TUBE SIDE 125 PSIG 188 PSIG
			DESIGN TEMP 250 F
			125 F

\*\*\* PRELIMINARY DRAWING NOT CERTIFIED FOR CONSTRUCTION \*\*\*

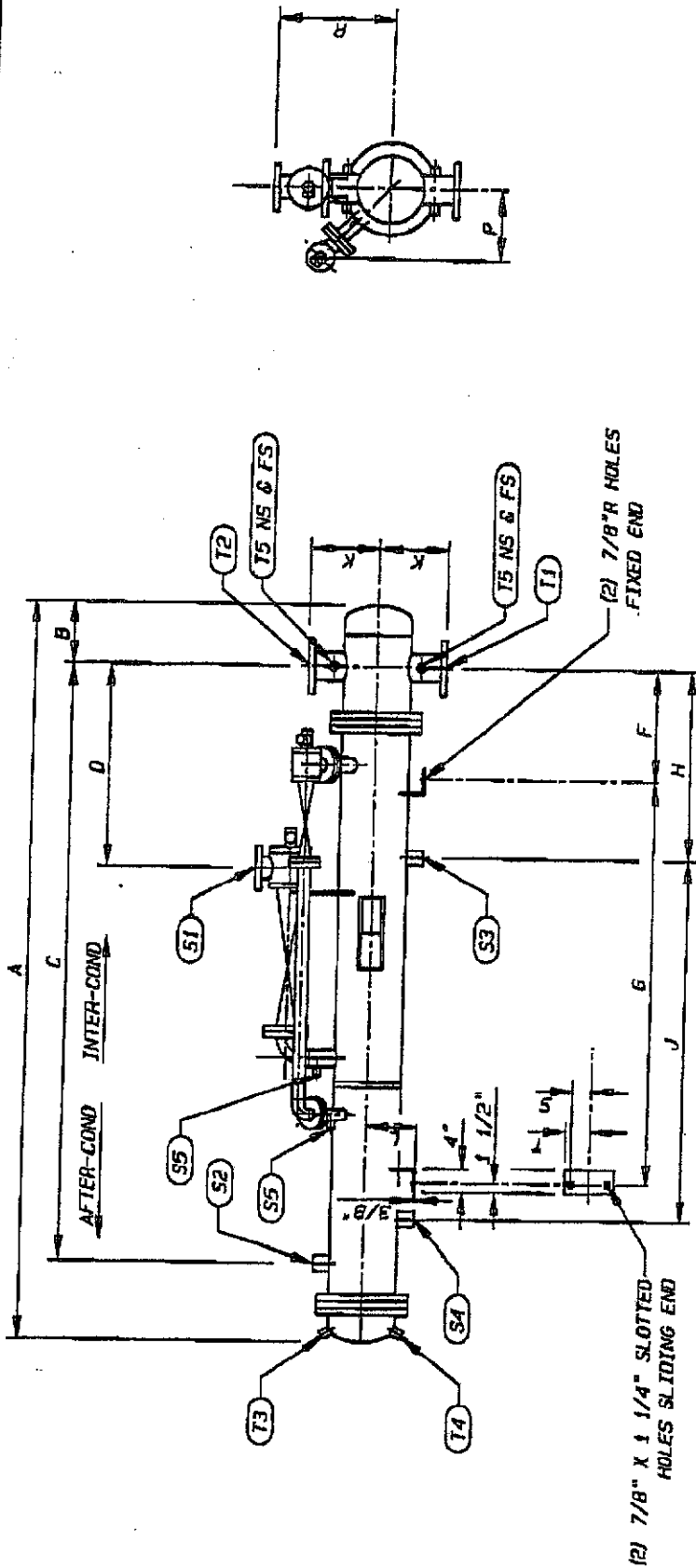

NOTE:  
CONNECTION FLANGES ARE ANSI STANDARD DRAUGHTING AND THICKNESS UNLESS OTHERWISE NOTED.

CUSTOMER Dresser-Rand  
CUSTOMER REF. RRF Expansion  
MODEL 1-32-080-2

SYMBOL	SIZE	TYPE	S-SHELL SIDE	T-TUBE SIDE	DIMENSIONS										
S1	3"	150# ANSI (FF)	VAPOR INLET	SERVICE	A	B	C	D	E	F	G	H	J		
S2	1 1/2"	NPT	VAPOR OUTLET		9'-8"	8 3/16"	8'-0"	2'-8"	17"	5'-5"	2'-6"	4'-11"			
S3	1 1/2"	NPT	CONDENSATE OUTLET		K	L	P	Q	R	S	T				
S4	1 1/2"	NPT	CONDENSATE OUTLET	TEST CONN.	10"	7"	10 5/16"	0	18 9/16"	2"	3"				
S5	1/2"	NPT	TEST CONN.										GRAHAM MANUFACTURING CO., INC.		
T1	3"	150# ANSI (RF)	WATER INLET										20 FLORENCE AVE. BATAVIA N. Y.		
T2	3"	150# ANSI (RF)	WATER OUTLET										PRELIMINARY EJECTOR PACKAGE		
T3	3/4"	NPT	VENT										SCALE MADE (CHKD APPD) DATE		
T4	3/4"	NPT	DRAIN										NONE KGG 10/09/95 DNG. NO. AB18AT95-2		
T5	3/4"	NPT	TEST CONN.										REV.		

**TURBINE PERFORMANCE**  
(OTHER POINT: 600 EKW)

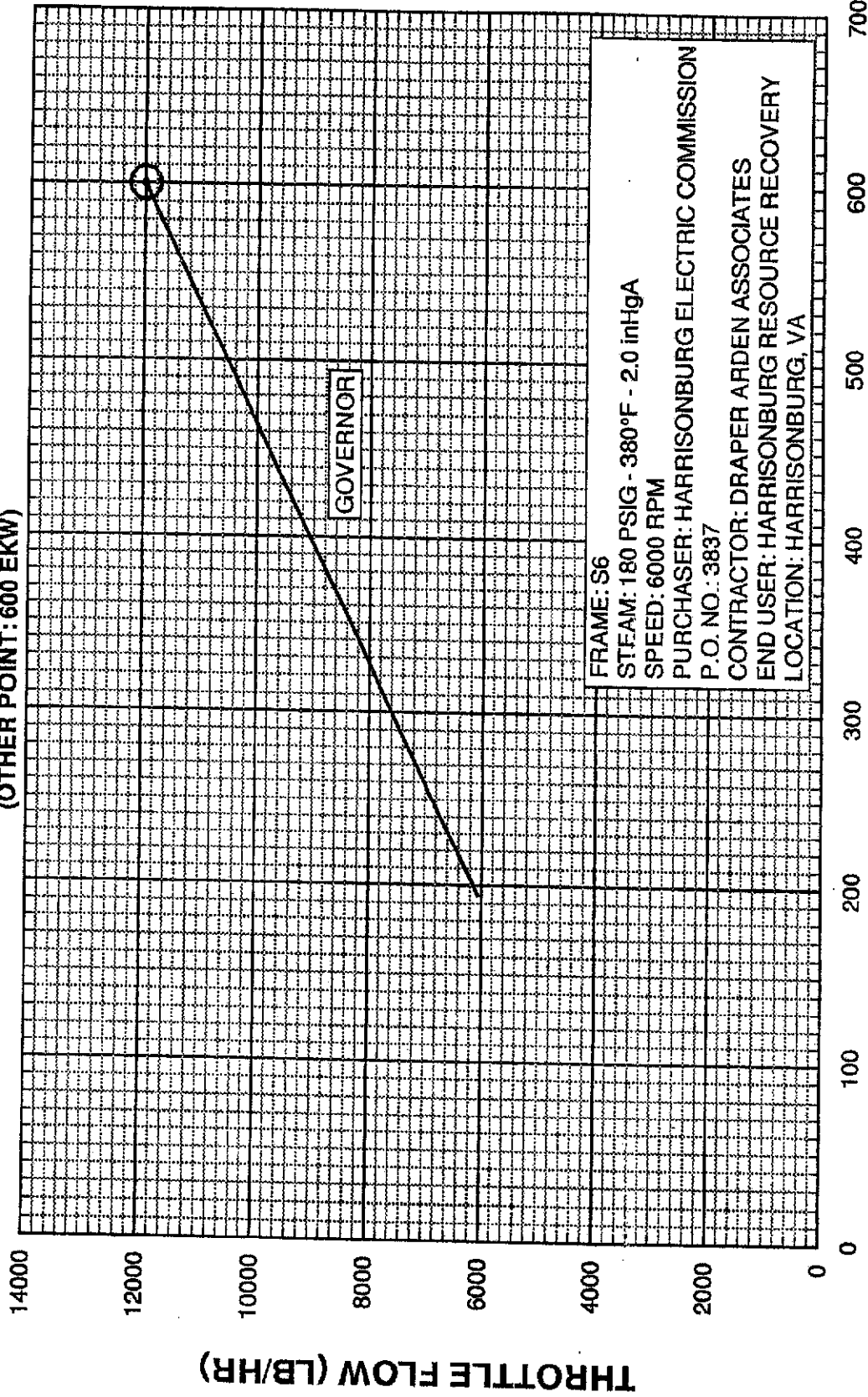

**FRAME: S6**  
**STEAM: 180 PSIG - 380°F - 2.0 inHgA**  
**SPEED: 6000 RPM**  
**PURCHASER: HARRISONBURG ELECTRIC COMMISSION**  
**P.O. NO.: 3837**  
**CONTRACTOR: DRAPER ARDEN ASSOCIATES**  
**END USER: HARRISONBURG RESOURCE RECOVERY**  
**LOCATION: HARRISONBURG, VA**

Drawn By: TDJ  
 Feb 28 1996

**DRESSER-RAND**

Steam Turbine Division  
 Wellsville, NY 14895 USA

U26361-1A  
 S/N: D4060



# TURBINE PERFORMANCE

(GUARANTEE POINT: 890 EKW)

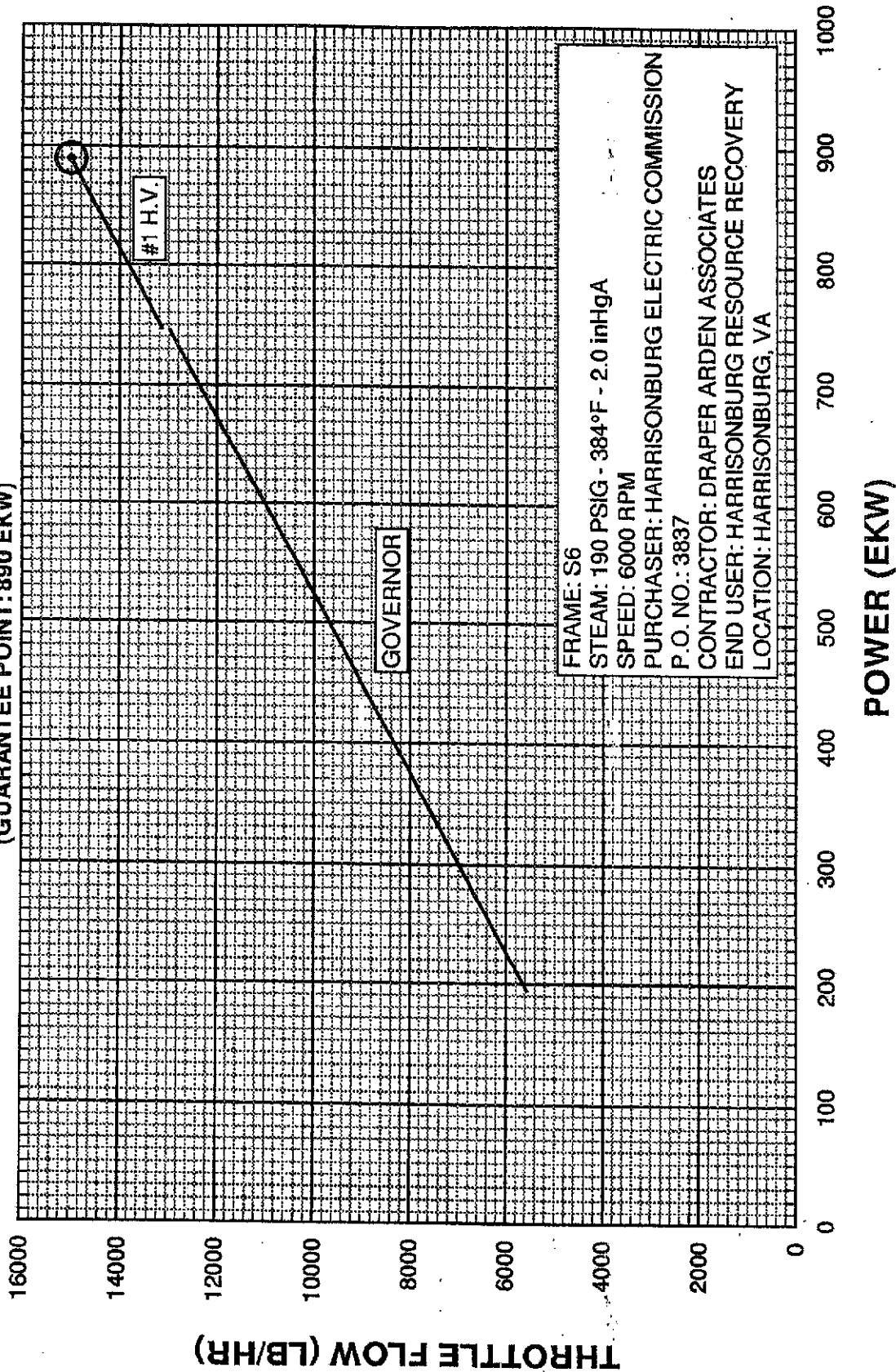

Drawn By: TDJ  
Feb 28 1996

DRESSER-RAND

Steam Turbine Division  
Wellsville, NY 14895 USA

U26361-1B  
S/N: D4060

# TURBINE PERFORMANCE

(RATED POINT)

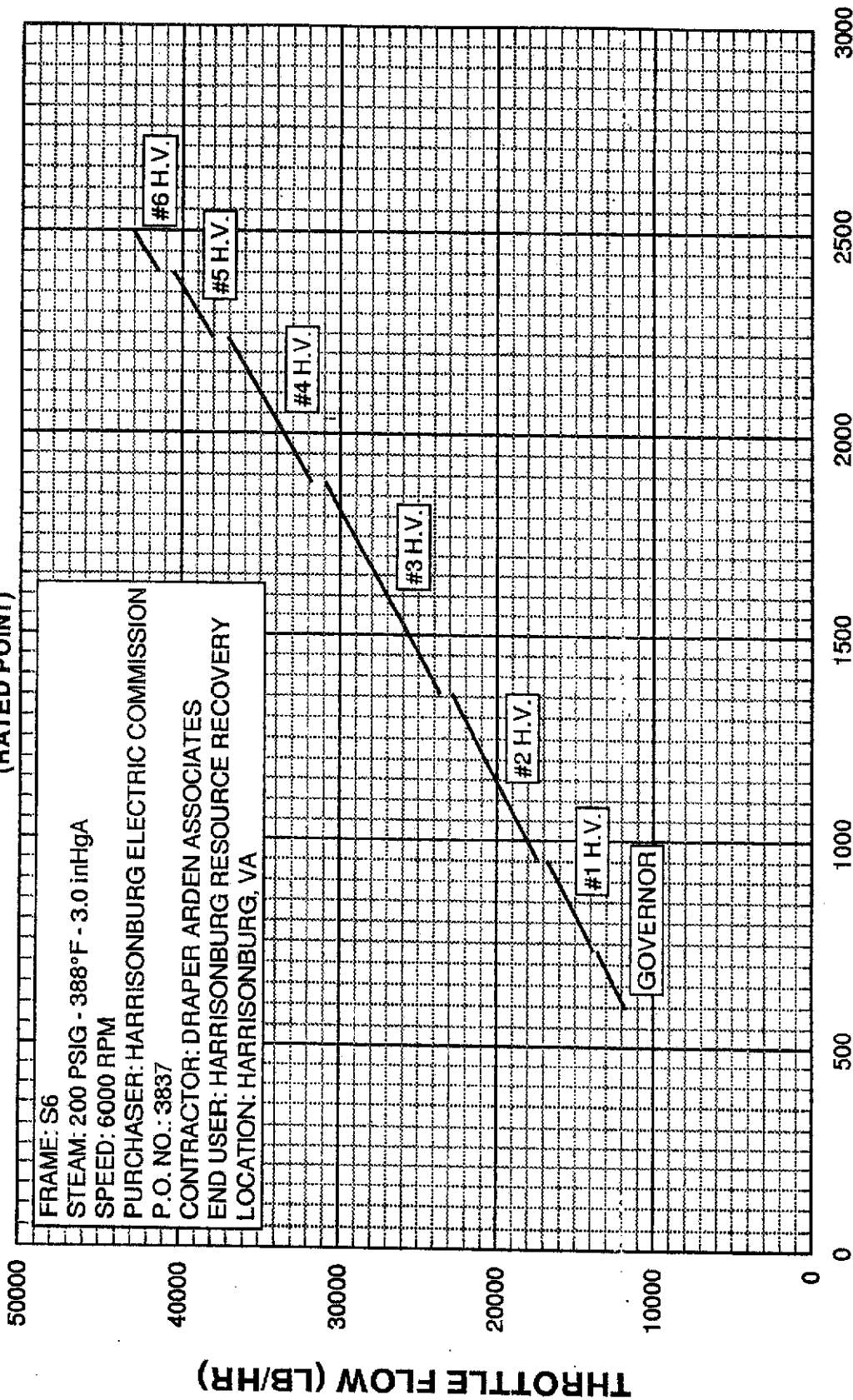

FRAME: S6  
 STEAM: 200 PSIG - 388°F - 3.0 inHgA  
 SPEED: 6000 RPM  
 PURCHASER: HARRISONBURG ELECTRIC COMMISSION  
 P.O. NO.: 3837  
 CONTRACTOR: DRAPER ARDEN ASSOCIATES  
 END USER: HARRISONBURG RESOURCE RECOVERY  
 LOCATION: HARRISONBURG, VA

POWER (EKW)

Drawn By: TDJ  
 Feb 28 1996

DRESSER-RAND Steam Turbine Division  
 Wellsville, NY 14895 USA

U26361-1C  
 S/N: D4060

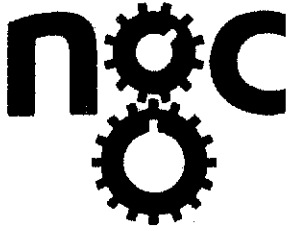

# Nuttall Gear Corporation

2221 Niagara Falls Blvd., P.O. Box 1032, Niagara Falls, N.Y. 14302  
716/731-5180 FAX 716/731-9329

---

CUSTOMER - DRESSER RAND

UNIT SIZE	SD 16-6L
ASSEMBLY POSITION	R.H.
CUSTOMER P.O. #	T-26361-5
GENERAL ORDER #	NC-2368
SHOP ORDER #	96R60785
HORSEPOWER	2500 KW
SERVICE FACTOR	1.3
RATIO	3.3261:1
INPUT RPM	5987
OUTPUT RPM	1800
GEAR DRIVE EFFICIENCY	98.6%



**DRESSER - RAND  
STEAM TURBINE DIVISION**

MAJOR STEAM CONNECTIONS

<u>REV.</u>	<u>CONN.</u>	<u>FLANGE</u>	<u>SIZE</u>	<u>ANSI</u>	<u>O.D.</u>	<u>B.C.</u>	<u>NO. HOLES</u>	<u>DIA. HOLES</u>	<u>MIN. FLG. THICKNESS</u>	<u>RAISED FACE</u>	<u>REMARKS</u>
	A	TURBINE INLET	6"	600#	14.00	11.50	12	1.12	1.88	.25 x 8.50	RIGHT SIDE
	B	TURBINE EXHAUST	30"	125#	38.75	36.00	28	1.38	2.12	F.F.	UP

AUXILIARY CONNECTIONS

<u>REV.</u>	<u>CONNECTION</u>	<u>NO.</u>	<u>SIZE &amp; TYPE CONNECTION</u>	<u>VALVE REQUIRED</u>	<u>VALVE SUPPLIED BY</u>	<u>CONNECT TO</u>	<u>REMARKS</u>
	C	1	3/4" 600# ANSI R.F.	YES	D-R	OPEN DRAIN	
	D	1	3/4" 600# ANSI R.F.	YES	D-R	OPEN DRAIN	
	E	1	3/4" FNPT	NO	----	OPEN DRAIN	
	F	1	3/4" FNPT	NO	----	OPEN DRAIN	
A	G	1	3/4" 600# ANSI R.F.	YES	D-R	OPEN DRAIN	
A	H	1	3/4" 300# ANSI R.F.	YES	D-R	OPEN DRAIN	
	J	1	3/4" 150# ANSI R.F.	YES	D-R	OPEN DRAIN	

7.0 DATA SHEETS

7.1 GENERAL

All data requested hereinafter shall be supplied with each proposal and will be used by the Engineer for evaluation purposes.

The Bidder shall answer all questions as briefly as possible. Where space does not permit sufficient description, the Bidder shall provide additional information such as drawings, cuts or typewritten descriptions.

Name of turbine manufacturer. DRESSER RAND

Name of generator manufacturer. IDEAL OR =

Name of excitation system manufacturer. IDEAL OR =

Name of governor manufacturer. WOODWARD OR =

Overall length. OUTLINE CE 213231 APPROX 295 INCHES

Overall width. " " " 125 INCHES

Overall height. " " " 110 INCHES

7.2 TURBINE/GENERATOR FEATURES

Type of turbine blades

Impulse (stage numbers) (7) SEVEN

Reaction (stage numbers) \_\_\_\_\_

With the governing valves wide open at design steam conditions, the turbine is expected to pass a throttle flow of 45000 lbs./hr.

Maximum continuous operating pressure 700 PSIG

Maximum continuous operating temperature 750 °F

7.2.1 Turbine Components:

Casing Material INLET & BARREL A216 GR WCB

Type of Support CENTERLINE

Type of Exhaust Flow (UP OR DOWN) CAST IRON A278, CL40

Rotor Material WHEELS A294 - FORGED  
SHAFT 4140 CL13C

Blade Design and Material 403 SS

Blade Shroud Design and Material 403 SS

Nozzle Rings Material 416 SS

Bearings Design and Material JOURNAL - TILT PAD  
THRUST - TILT PAD

Seals Design and Material LABY - NI RESIST

Inlet Steam Chest Design and Material A216 GR WCB  
CAST STEEL

Inlet Steam Valve Design and Material A351, G0420SS

7.2.2 Governor:

Type and Design  
(include catalog cuts or drawings)

WOODWARD ELECTRONIC

Oil System Design

NONE REQ'D

Pump Design

NONE REQ'D

Accuracy (furnish complete details)

CLASS D

7.2.3 Trip and Throttle Valve:

Design and Material

700PSIG 750°F

Integral Strainer Design and Material

ST. ST.

7.2.4 Rotor Balance (Tolerance)

PER NEMA

7.2.5 Lubrication System:

PRESSURE LUBE

Type and Design

INTEGRAL

Main Oil Pump Design

POSITIVE DISPLACEMENT

A.C. Auxiliary Pump Design

" "

D. C. Auxiliary Pump Design

" "

Location

IN CASE

Sump Tank Design and Capacity

LATER

Sump Tank Accessories:

PER SPEC

Air/Vapor Removal System

BLOWER

Heaters (Design)

INCLUDED

Lube Oil Control System (Furnish Drawings,  
Catalog Cuts, Etc.)

SEE TYPICAL  
DRG # CE 213444

7.2.6 Shaft Sealing System:

Type and Design

Labyrinth / AUTOMATIC  
SYSTEM

Equipment Furnished (Manufacturer, Size, Flow,  
Materials of Construction, Etc.):

LATER

Steam Jet Ejector Design

"

Ejector - Steam Condenser Design

"

Cooling Water Flow

"

7.2.7 Turbine Gauge Board, Generator/Synchronizing Panel & Switchgear:

Describe Type, Design and Proposed Location

PER SPEC

7.2.8 Generator:

SEE SEPERATE GENERATOR  
SHEETS

Rated KVA capability

Generator Reactances

Zero sequence at rated current  $X_0$

Negative sequence at rated voltage  $X_2$

Subtransient at rated voltage  $X'd$

Transient at rated current  $X'd$



Synchronous at rated current X'd \_\_\_\_\_

SCR at rated KVA \_\_\_\_\_

Generator efficiency at rated kVA and rated power factor \_\_\_\_\_ %

Generator regulation at rated power factor 75% kVA \_\_\_\_\_ ,  
100% rated kVA \_\_\_\_\_ , and 110% rated kVA \_\_\_\_\_ .

7.2.9 Excitation System:

Excitation, voltage \_\_\_\_\_ , Amperes \_\_\_\_\_ .

Type of excitation System:

static \_\_\_\_\_

brushless alternator \_\_\_\_\_

Can field temperature, voltage and current  
be measured directly? (Yes or No) \_\_\_\_\_

If so, how? \_\_\_\_\_

Electrically-operated field breaker? (Yes or No) \_\_\_\_\_

Transformer: KVA \_\_\_\_\_ Primary Volts \_\_\_\_\_ Secondary Volts \_\_\_\_\_

Type insulation? Oil \_\_\_\_\_ Dry \_\_\_\_\_ .

Approximate weight? \_\_\_\_\_ .

Electrically-operated Primary Air Circuit Breaker? Yes \_\_\_\_\_ No \_\_\_\_\_ .

I. C. MVA \_\_\_\_\_

F. L. Amperes \_\_\_\_\_

Brushless Alternator: KVA \_\_\_\_\_ Volts \_\_\_\_\_

Rectifier: Rotating \_\_\_\_\_ Stationary \_\_\_\_\_

Diodes Accessible During Operation? YES \_\_\_\_\_ No \_\_\_\_\_

Voltage Regulator

Manufacturer \_\_\_\_\_

Type \_\_\_\_\_ Model \_\_\_\_\_

7.2.10 Neutral Grounding Provision

Reactor \_\_\_\_\_ Resistor \_\_\_\_\_

OHM rating \_\_\_\_\_ Ampere rating \_\_\_\_\_

7.2.11 Structural Requirements:

Total Weight (lbs) ~ 60,000 SEE OUTLINE CE 213231  
TURBINE/GEAR/GEN./BASE/LADE

Weight of Individual Components (List):

Component	(lbs)
TURBINE	12000
GEAR	4000
GENERATOR	22000
BASEPLATE	18000
ACCESSORIES	2000
CONDENSER	30000
SWITCHGEAR	4000

7.2.12 Speed Reducing Gear (If not Direct Coupled)

Manufacturer NUTTALL OR LYFKIN  
 Type and Design SINGLE REDUCTION  
 Rated Horsepower and Service Factor 2500 KW 1.3  
 Input Shaft Speed 6000  
 Output Shaft Speed 1800  
 Horsepower Losses at 100% INCLUDED and 50% of rated power -  
 Cooling Design and Requirements PART OF LUBE SYSTEM  
 Lubrication Design PRESSURE LUBE

2.13 Turbine-Generator Performance

SEE PROPOSAL SHEET

Throttle Flow lb/hr (@ 190 PSIG & 384 °F)	50,000	40,000	25,000	Max	Min
Exhaust Enthalpy Btu/lb	_____	_____	_____	_____	_____
Generator Output (KVA)	_____	_____	_____	_____	_____
Steam Rate (lb/kwh)	_____	_____	_____	_____	_____

CONDENSER

SEE PROPOSAL SHEETS

1 Manufacturer:

Name: GRAHAM

Location: BATIVIA NY

2 Condenser surface area (total effective): \_\_\_\_\_ sq. ft.