

*/ Marley Class F400 Cooling Tower /*





## Proven Design

## Improved Structural Materials

The Marley industrial counterflow cooling tower has proven itself as one of the most efficient and reliable designs ever. The F400 cooling tower is a logical engineered evolution of this proven design, making use of pultruded fiberglass shapes as structural members.

Proven through years of successful chemical plant construction, pultruded fiberglass is ideal for the wet, corrosive cooling tower environment. It's strong like steel but at a fraction of the weight. Yet, it will not corrode from chemical exposure or moisture, and it resists deterioration from sunlight.



## Design Integrity

The F400 cooling tower elevates the proven Marley structural design to an even higher level of dependability and performance.

### ■ Theory Equals Performance

The engineering properties of Marley fiberglass structural members are predictable and consistent. Laboratory testing verifies the structural designs before their application in cooling towers.

### ■ Quality Structural Connections

Bolted, non-glued design provides the highest reliability under the most adverse conditions. Stainless steel fasteners are used throughout the F400 in conjunction with bearing sleeves to minimize fiberglass shear stress in the bolted joints.

### ■ Permanent Structural Stability

Marley structural designs reflect the actual conditions of heat, moisture and dynamic loading encountered in cooling towers. These structures are up to the task!

## Design Flexibility

F400 towers are available in numerous basic cell sizes. Length and width may vary in 6'-0" increments. Tower height, fill height, and fill density are also variable.

Within each cell size, our designers can choose from numerous possible component combinations. Several options may result in economical selections capable of the thermal performance requirements, but only one will optimally satisfy the fan horsepower, pump head, plan area, and other evaluation parameters contained in your specifications.



Our design engineers use the Total System Approach to review each cooling tower application to assure that the components selected will work together as an integrated system for efficient performance and long life—the proven systematic approach to cooling tower design.



*Total System Approach—Our proven systematic approach to cooling tower design.*

### ■ Fast, Efficient Construction

All parts are cut and predrilled to exact specifications at Marley factories.

### ■ Safety and Strength

The F400 fandeck is constructed of Marley DuraLast textured pultruded fiberglass panels with integrated, hidden stainless fasteners, providing an anti-slip, safe walking surface.

### ■ Architectural Casing

Options include Marley DuraLast pultruded casing with integrated, hidden stainless fasteners and enclosed fandeck or durable V-Rib FRP casing.

### ■ Tested and Proved Fan Designs

Marley fans are designed using test data from wind tunnel modeling at the SPX Cooling Technologies Research and Development Center and are performance verified at operating installations, ensuring performance as specified.

### ■ Peak Fan Performance

Marley FRP fan cylinders feature venturi shaped eased inlets and close blade tip clearances.

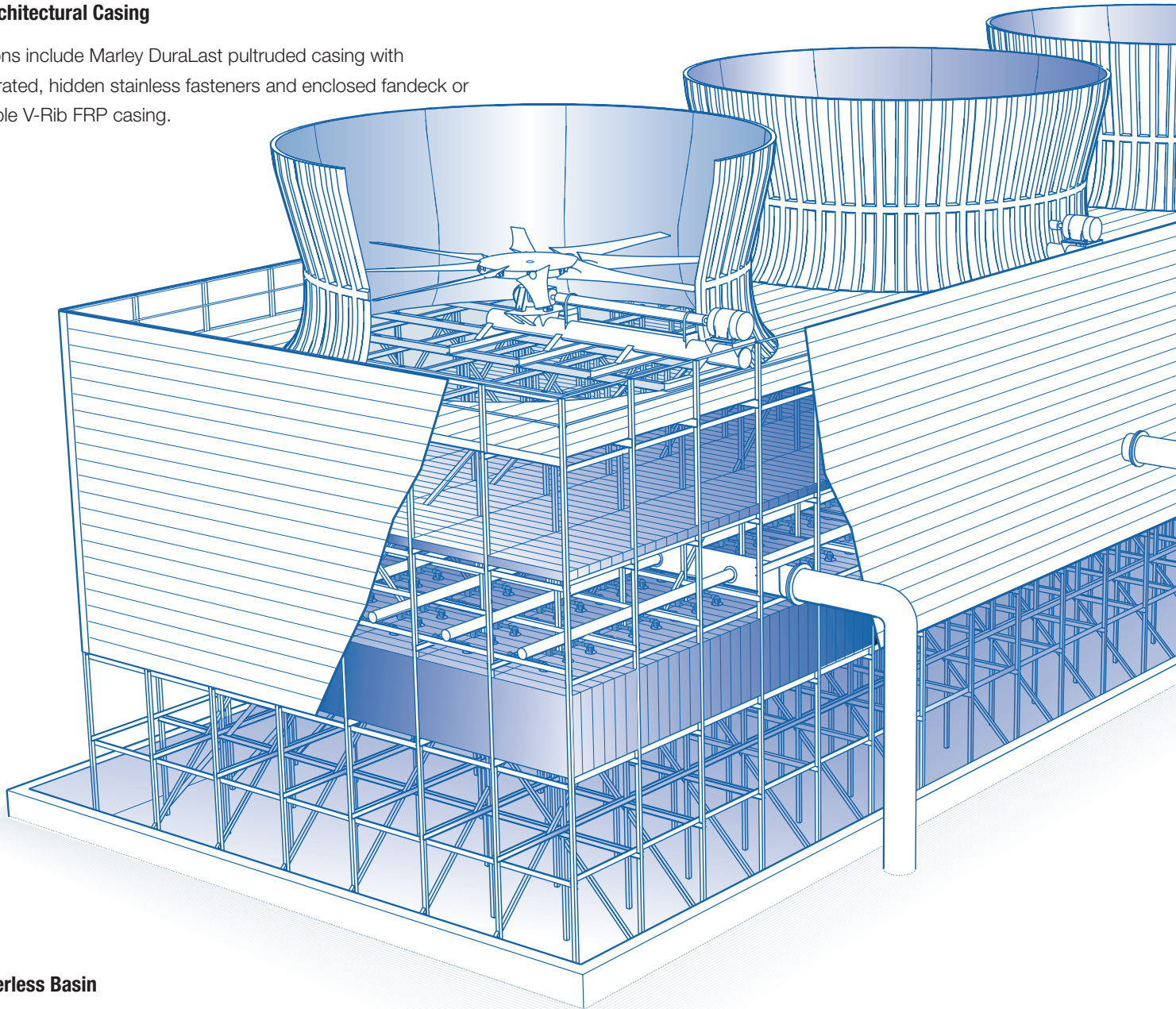

### ■ Pierless Basin

The F400 structure can be anchored to a flat basin floor or designed to fit existing basins. Fewer piers mean lower basin cost.

### ■ Low Drift Rates

Marley XCEL® cellular PVC eliminators offer the lowest drift rates in the industry. XCEL eliminators significantly lower air pressure losses, reducing fan horsepower requirements thus saving energy costs.

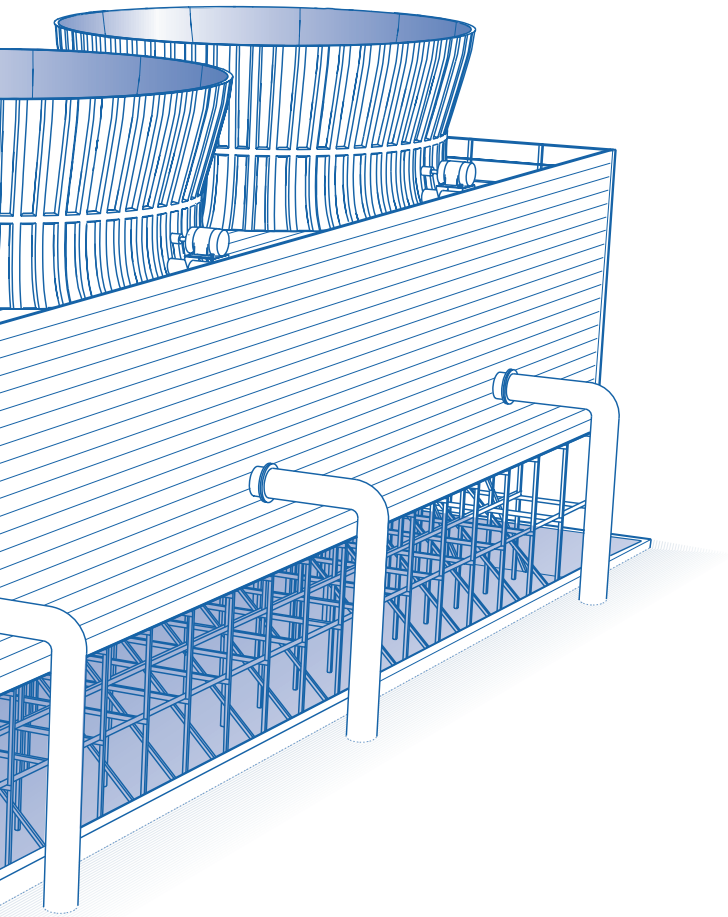

### ■ Rugged Marley Driveshaft

Built from stainless steel or carbon fiber composite tubes with stainless steel flanges. All Marley Driveshafts are dynamically balanced at the factory to minimize operating vibration resulting in smooth, long lasting fan operation.

### ■ Simple Maintenance

Each Geareducer is equipped with an oil level gauge outside of the fan cylinder near the motor. Service fittings at the gauge facilitate changing Geareducer oil.

### ■ Completely Bolted Structure

Marley F400 fiberglass structures are completely and securely assembled using mechanical stainless fasteners without the use of adhesives. Benefits of a bolted structure are:

Assembly can be done in the cold or wet weather—adhesives are not recommended below 40°F plus the surface must be dry before gluing.

Every joint is guaranteed to be as specified whereas a glued joint is only as good as the preparation made prior to the assembly.

If any member has to be replaced for any reason, it's a simple matter of unbolting the structure and adding the new part.

### ■ Tough High-Performance Film Fill

Marley high-performance fill removes process heat efficiently and predictably. PVC fill sheets are thermoformed at Marley factories to exacting quality and strength standards. Maximum performance fill designs and clog resistant fill designs are available for a wide range of thermal and water quality requirements. Our design engineers evaluate each cooling tower application individually using computer optimization analysis to select the best fill system, maximizing thermal performance—and keeping power consumption to a minimum.

### ■ Clog-Resistant NS Nozzles

NS nozzles are the heart of the F400 water distribution system assuring unimpeded, uniform flow with minimal operating pump head. Large diameter NS nozzles free you from the expense and nuisance of cleaning clogged, overly-complicated nozzle designs. The NS nozzle has a consistent “solid-cone” downspray pattern to assure uniform distribution coverage at pressures as low as two feet of water.

### ■ Durable Marley Geareducer

The industry quality standard. Designed to meet and exceed the requirements of CTI STD-111 and AGMA standards. Every Geareducer is run-in under load at the factory. Numerous reduction ratios are available so that horsepower is applied at optimum fan speed.

## Combining over 80 Years of Cooling Tower Experience With over 50 Years of Fiberglass Experience

Marley began using composites in cooling towers in the early 1950s, when they were considered “exotic materials”. In fact, Marley’s work with what was then called GRP (glass-reinforced polyester) was so extensive that we were issued a registered trademark for GRP in 1960. Since then, commercial formulations have been generically known as FRP (fiber-reinforced polyester).

Through a process called pultrusion, fiberglass components can be produced to even higher standards. Components in the F400 cooling tower meet the stringent Marley requirements for consistent strength and predictable performance.

Pultruded structural components are used throughout the F400 cooling tower to produce an engineered framework of unsurpassed quality, reliability and safety. And, the F400’s structural components will always be available for simple, economic repairs.

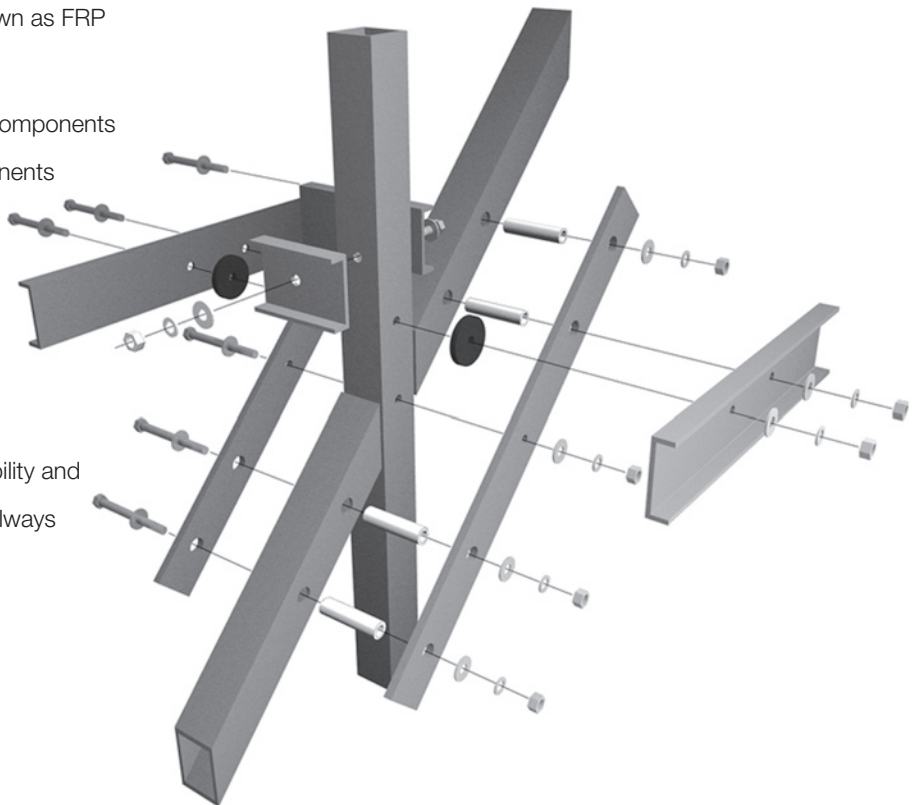

## Fiberglass Pultrusion Fits The Marley “Total Systems” Approach

The pultrusion process produces a product with definite, predictable, and measurable performance. Extensive laboratory, university, and field testing for long-term effects of deflection, bending, shear, buckling, and temperature has enabled us to simulate and evaluate its performance.

Advantages of pultrusion structural members:

### ■ High Strength

Structural pultrusions approximate the strength of steel in tension and compression.

### ■ Light Weight

80% less than steel, 30% less than aluminum.

### ■ Corrosion Resistance

Impervious to a broad range of corrosive materials; immune to deterioration.

### ■ Quality Construction

Cut and predrilled to exact specifications at Marley factories, fiberglass pultrusions will not warp, twist, or split after fabrication which simplifies field assembly and component replacement. And, tower construction is safe, reliable and efficient using pultruded structural components.

### ■ Wet/Dry Operation

Fiberglass is perfect for “cycled” cooling towers as it is naturally impervious to splitting and checking.

### ■ Non-Conductive

Reduces the hazard of electrical shock compared with metal structure towers.

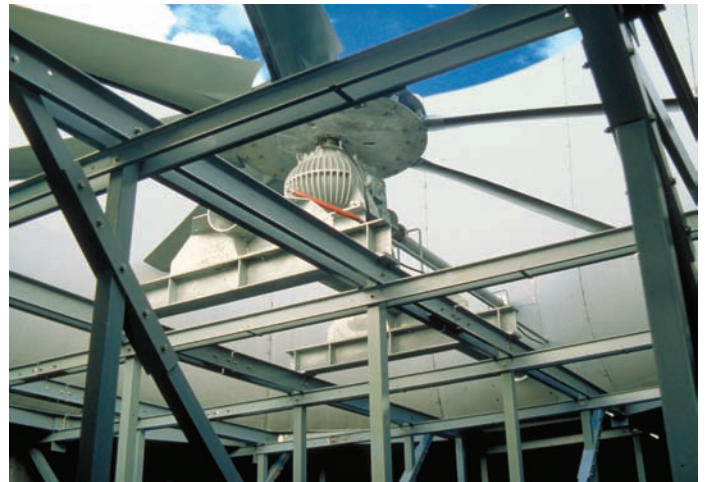

### ■ No Preservative Treatment Chemicals

are used in the cooling tower structure.

### ■ Fire-Resistant Formulations

are available as an option.

## At Your Service

SPX Cooling Technologies offers a variety of additional services to owners of cooling towers worldwide. Services include:

- Application/Sizing/Layout
- Construction
- Parts
- Maintenance
- Condition Evaluation
- Reconstruction
- Performance Enhancement
- Tower Replacement

If we can help you in any way, please feel free to call SPX Cooling Technologies' world headquarters. By calling 913 664 7400, we'll put you in touch with a Marley sales representative in your area or you can find your Marley sales representative on the internet at [spxcooling.com](http://spxcooling.com).

## The Marley Difference

The companies that form SPX Cooling Technologies have over 120 years of cooling tower experience. Today, we have towers of every size and shape in over 75 countries worldwide.

Everything about your Marley cooling tower will be designed as an integrated system. Marley's "Total Systems" approach includes proven in-house capability to develop your tower from analysis of needs to every step in between.

Best of all, because Marley cooling towers are designed, constructed, and backed up as an integrated system, every component is warranted by a single supplier, SPX Cooling Technologies.

## Product Specifications

*Product Specifications* SPEC F-400 detail the tower in the form of specification language and provide technical as well as common-sense information on the importance of your specifications. See your Marley sales representative for a copy or download from the web at [spxcooling.com](http://spxcooling.com).



**SPX**<sup>®</sup>

**COOLING TECHNOLOGIES**

7401 WEST 129 STREET  
OVERLAND PARK, KANSAS 66213  
UNITED STATES  
913 664 7400  
[spxcooling@spx.com](mailto:spxcooling@spx.com)  
[spxcooling.com](http://spxcooling.com)

In the interest of technological progress, all products are subject to design and/or material change without notice.  
©2008 SPX Cooling Technologies, Inc.  
Printed in USA | F400-05A



*/ Marley Class F400 Cooling Tower /*

*Product Specifications*



## Marley / Class F400 Cooling Tower / Contents

---

### Specifications / Base

---

Base	4
Thermal Performance	4
Design Loading	5
Circulating Water Quality	5
Structure	6
Fan Deck and Fan Cylinders	7
Fill and Drift Eliminators	8
Mechanical Equipment	8
Casing	10
Hot Water Distribution System	10
Cell Partitions	11
Access and Safety	11
Scope of Work	12

### Specifications / Options

---

#### Premium Hardware Options

Level 1 - Epoxy-Coated Galvanized Steel	13
Level 2 - Type 316 Stainless Steel	13
Level 3 - Silicone Bronze	14

#### Driveshaft Material Options

All Stainless Steel Driveshaft	15
Carbon Fiber Driveshaft / Stainless Steel Couplings	15

#### Access and Maintenance Options

Fiberglass Ladder	16
Steel Ladder	16
Second Stairway at End of Tower	16
Cased Stairway	16
Mechanical Equipment Temporary Access Catwalk	17
Mechanical Equipment Permanent Access Catwalk	17
Endwall Davit	17

#### Miscellaneous Options

Fan Cylinder View Port	18
Control System	18
Vibration Limit Switch	19
Low Oil Switch	19

## Marley / Class F400 Cooling Tower /

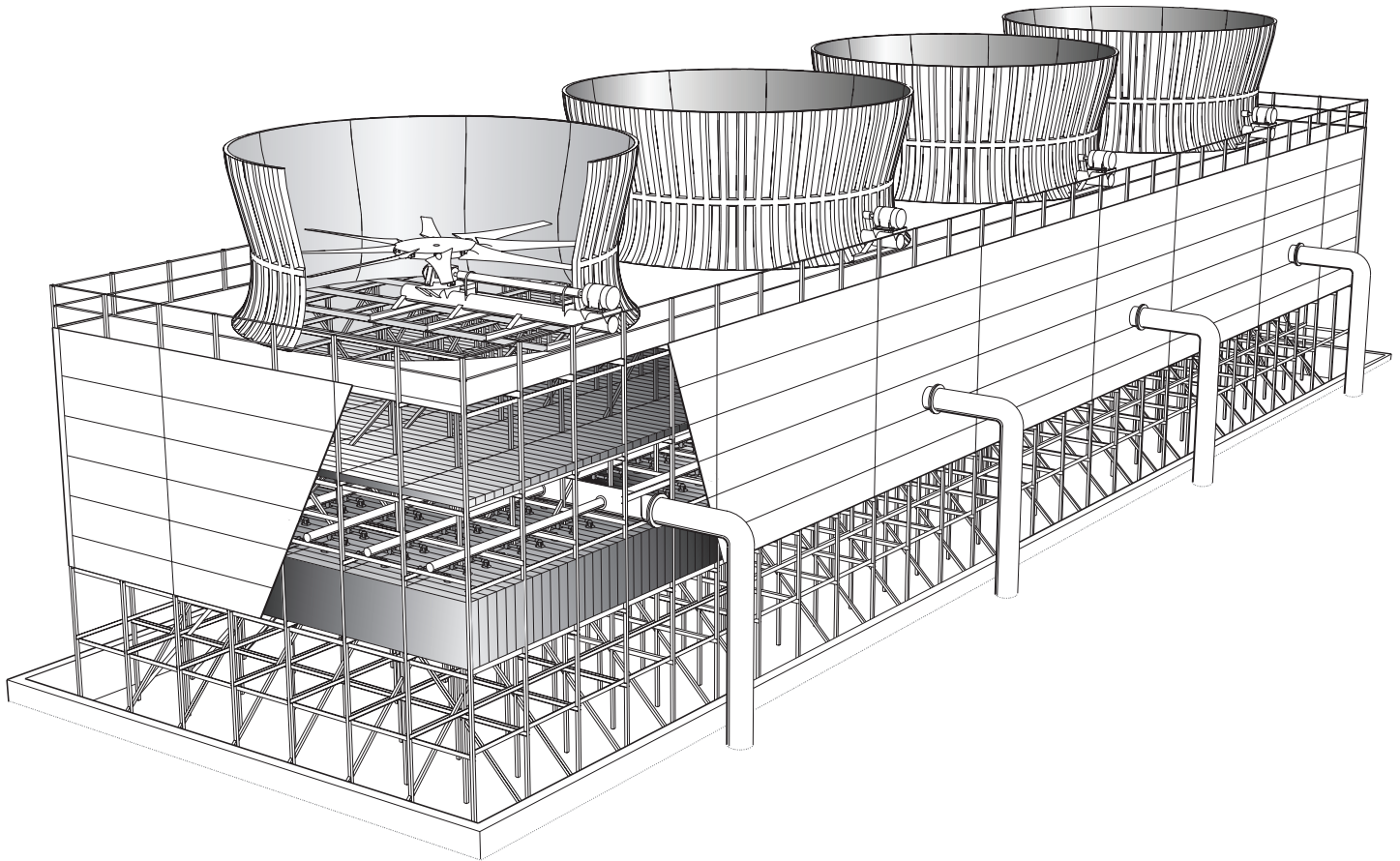

**M**arley Class F400 towers are field erected, heavy duty, film fill, counterflow cooling towers, designed to serve all normal cooling water systems. Structural components are inert fiberglass composite pultrusions. The F400 cooling tower represents the current generation of towers that were the basis of Marley's entrance into the cooling tower marketplace in the 1920s, and incorporate over 75 years of design advancements that our customers have found valuable. The Marley F400 represents the current state of the art in this cooling tower category.

This publication not only relates the language to use in describing an appropriate F400 cooling tower—but also defines why certain items and features are important enough to specify with the intention of insisting upon compliance by all bidders. The left hand column of all pages provides appropriate text for the various specification paragraphs, whereas the right hand column comments on the meaning of the subject matter and explains its value.

Pages 4 through 12 indicate those paragraphs that are descriptive of a cooling tower which will not only accomplish the specified thermal performance, but which will include all normal operation and maintenance enhancing accessories and features. It will also incorporate those standard hardware materials which testing and experience has proven to provide best results in normal operating conditions.

Pages 13 through 19 provide some paragraphs intended to add those features, components, and materials that will customize the tower to meet the user's requirements.

Space does not permit definition and explanation of all of the possible options that can be applied to the Class F400 cooling tower. We realize that you, the purchaser, must be happy with the tower's characteristics, and we are prepared to provide—or provide for—any reasonable enhancement that you are willing to define and purchase.



**Marley / Class F400 Cooling Tower / Specifications: Base**

Specifications	Specification Value
<p><b>1.0 Base:</b></p> <p><b>1.1</b> Furnish and install an induced draft, counterflow type, field erected, fiberglass framed, film fill, industrial duty cooling tower of ____ cell(s), situated as shown on the site plan. The limiting overall dimensions of the tower shall be ____ ft wide x ____ ft long x ____ ft high to the top of the fan cylinders. Total operating horsepower of the fans shall not exceed ____ hp.</p>	<p>■ The base of your specification establishes the type, configuration, base material, and physical limitations of the cooling tower to be quoted. During the planning and layout stages of your project, you may have focused your attention on a cooling tower selection that fit your space allotment, and whose power usage was acceptable. Limitations on physical size and total operating horsepower avoid the introduction of unforeseen operational and site-related influences. Even further control of this problem will result if you specify the number of cells, and the maximum fan hp/cell.</p> <p>You are specifying a counterflow tower, which is a type noted—and usually specified—for its economical use of ground space on projects where the required thermal performance is very difficult. The one you have chosen to specify utilizes film-fill, which normally provides maximum cooling effect in significantly less area than would be required by a splash-fill cooling tower.</p> <p>You are also specifying materials of construction which are impervious to the ills that beset towers constructed of more traditional materials. Life expectancy is not typically a characteristic of concern in this tower.</p> <p><b>Note:</b> If it is your intention to evaluate offerings on the basis of first cost, plus the cost of ownership and operation, please be clear on your inquiry documents regarding the parameters under consideration, as well as the value that you intend to place upon each of them. (i.e. dollars per hp; dollars per ft of pump head; dollars per sq ft of basin area, etc.) They <b>will</b> affect the sizing of the tower.</p>
<p><b>2.0 Thermal Performance:</b></p> <p><b>2.1</b> The tower shall be capable of cooling _____ GPM of water from ____ °F to ____ °F at a design entering air wet-bulb temperature of ____ °F. The cooling tower manufacturer shall guarantee that the tower supplied will meet the specified performance conditions when the tower is installed according to plans. If, because of a suspected thermal performance deficiency, the owner chooses to conduct an on-site thermal performance test in the presence of the manufacturer, and under the supervision of a qualified, disinterested third party in accordance with CTI (Cooling Technology Institute) ATC-105 standards during the first full year of operation; and if the tower fails to perform within the limits of test tolerance; then the cooling tower manufacturer shall make alterations as it deems necessary to overcome indicated deficiency. Should alterations prove to be inadequate, the owner, at the cooling tower manufacturer's option, shall be compensated by either (or a combination of both) of the following: (a) Installation of additional cooling tower capacity; (b) A refund of a percentage of the contract price proportional to the deficiency as established.</p>	<p>■ Your reason for purchasing a cooling tower is to obtain a continuing flow of cooled water as defined in the first paragraph at left. If the tower that you purchase is incapable of performing as specified, then you will not have received full value for your money.</p> <p>Bear in mind that the size—and cost—of a cooling tower varies directly with its true thermal capability. This paragraph is intended to protect you against either intentional or inadvertent undersizing of the tower by the manufacturer. Judging the level of performance of a cooling tower on critical processes is never easy, and the potential risk of a non-performing cooling tower usually causes the requirement for a mandatory acceptance test to be very desirable.</p> <p>Your contract with the successful bidder should establish the acceptable remedies for missed performance, which might include:</p> <ul style="list-style-type: none"> <li>• The addition of one or more cells of tower, as necessary, to bring the cooling tower to the specified level of performance. This is usually limited to the scope of work as defined in the specifications, which means that you (the owner) will have to pay for the additional basin, wiring, starters, piping, etc.</li> <li>• The reimbursement of a portion of the total contract price equal to the percentage deficiency in performance.</li> </ul> <p><b>Under no circumstances should you allow the manufacturer to repitch the fans to increase motor brake horsepower above that shown in the proposal. That creates additional operating costs that will continue for the life of the tower—and imposes no penalty on the manufacturer.</b></p>

## Marley / Class F400 Cooling Tower / Specifications: Base

Specifications	Specification Value																																												
<p><b>3.0 Design Loading:</b></p> <p><b>3.1</b> The tower and all its components shall be designed to withstand a wind load based on ASCE-7 and a seismic load based on UBC. As a minimum, a stability load of 2 1/2% shall be applied to the structure. For non-domestic jobs, a minimum design wind load of 30 psf shall be used. Fan decks and other work levels shall be designed for a uniform load of 60 psf, or a concentrated live load of 600 lbs. Allowable deflection at 60 psf uniform load shall be 1/180 of span. Fill and fill supports shall be capable of withstanding a 40 psf live load. Guardrails shall be capable of withstanding a concentrated live load of at least 200 lb applied in any direction at any point along the top rail.</p> <p><b>4.0 Circulating Water Quality:</b></p> <p><b>4.1</b> It is anticipated that the circulating water will have the following characteristics:</p> <table style="width: 100%; border-collapse: collapse;"> <tr> <td style="width: 70%;">pH range</td> <td style="width: 10%; text-align: center;">_____</td> <td style="width: 10%; text-align: center;">to</td> <td style="width: 10%; text-align: center;">_____</td> </tr> <tr> <td>Chlorides (NaCl)</td> <td style="text-align: center;">_____</td> <td></td> <td style="text-align: center;">ppm</td> </tr> <tr> <td>Sulfate (SO<sub>4</sub>)</td> <td style="text-align: center;">_____</td> <td></td> <td style="text-align: center;">ppm</td> </tr> <tr> <td>Sodium Bic. (NaHCO<sub>3</sub>)</td> <td style="text-align: center;">_____</td> <td></td> <td style="text-align: center;">ppm</td> </tr> <tr> <td>Calcium (CaCO<sub>3</sub>)</td> <td style="text-align: center;">_____</td> <td></td> <td style="text-align: center;">ppm</td> </tr> <tr> <td>Oil or grease</td> <td style="text-align: center;">_____</td> <td></td> <td style="text-align: center;">ppm</td> </tr> <tr> <td>Silica (SiO<sub>2</sub>)</td> <td style="text-align: center;">_____</td> <td></td> <td style="text-align: center;">ppm</td> </tr> <tr> <td>Max water temperature</td> <td style="text-align: center;">_____</td> <td></td> <td style="text-align: center;">°F</td> </tr> <tr> <td>Total suspended solids</td> <td style="text-align: center;">_____</td> <td></td> <td style="text-align: center;">ppm</td> </tr> <tr> <td>Bacteria count</td> <td style="text-align: center;">_____</td> <td></td> <td style="text-align: center;">cfu/ml</td> </tr> <tr> <td>(Other)</td> <td colspan="3" style="border-bottom: 1px solid black;"></td> </tr> </table> <p><b>4.2</b> The specifications, as written, are intended to indicate those materials that will be capable of withstanding the above water quality in continuing service. They are to be regarded as minimum requirements. Where components peculiar to individual tower designs are not specified, the manufacturer shall take the above water quality into account in the selection of their materials of manufacture.</p>	pH range	_____	to	_____	Chlorides (NaCl)	_____		ppm	Sulfate (SO <sub>4</sub> )	_____		ppm	Sodium Bic. (NaHCO <sub>3</sub> )	_____		ppm	Calcium (CaCO <sub>3</sub> )	_____		ppm	Oil or grease	_____		ppm	Silica (SiO <sub>2</sub> )	_____		ppm	Max water temperature	_____		°F	Total suspended solids	_____		ppm	Bacteria count	_____		cfu/ml	(Other)				<p>■ Although very strong, molded FRP decking material is relatively flexible. For this reason, it is important to limit deflection at design load to no more than 1/180 of span. Otherwise, decking and working platforms would be much too springy for the appropriate and comfortable handling of equipment.</p> <p>The indicated design values are the minimum allowables under normal design standards. If your geographic location dictates higher wind load, seismic load, or deck loading values, please make the appropriate changes.</p> <p>■ For purposes of this specification, “normal” circulating water conditions are defined as follows:</p> <ul style="list-style-type: none"> <li>• A pH level between 6.5 and 9.0.</li> <li>• A chloride content below 750 ppm (as sodium chloride) – or below 455 ppm (as chloride).</li> <li>• A sulfate content (SO<sub>4</sub>) below 1200 ppm. (Sulfates can attack concrete, and contribute to scale.)</li> <li>• A sodium bicarbonate (NaHCO<sub>3</sub>) content below 300 ppm.</li> <li>• Calcium (CaCO<sub>3</sub>) below 800 ppm.</li> <li>• Oil and/or grease negligible.</li> <li>• Silica (SiO<sub>2</sub>) below 150 ppm.</li> <li>• A maximum hot water temperature of 120°F.</li> <li>• Total suspended solids (TSS) below 50 ppm.</li> <li>• A bacteria count &lt;10,000 cfu/ml.</li> <li>• No significant contamination with unusual chemicals or foreign substances.</li> </ul> <p>If your circulating water quality falls outside any of the parameters listed above, some changes in the materials specifications may be required, most of which are listed on pages 13 thru 15. Where there is any question in your mind, please provide Marley with an analysis of your makeup water, along with the number of concentrations you intend to permit in your circulating water. Better still, since the quality of the water in a cooling tower soon reflects the quality of the surrounding air, an analysis of the circulating water from another cooling tower on site, if one exists, might be very informative.</p> <p>Except for those unusual operating situations where the circulating water may be so laden with suspended solids, algae, fatty acids, product fibers, active organisms reflected in BOD, and the like that plugging of the cooling tower fill is a probability, reasonable attention to the hardware materials and/or their coatings is all that is normally required. Please work with your Marley sales representative.</p>
pH range	_____	to	_____																																										
Chlorides (NaCl)	_____		ppm																																										
Sulfate (SO <sub>4</sub> )	_____		ppm																																										
Sodium Bic. (NaHCO <sub>3</sub> )	_____		ppm																																										
Calcium (CaCO <sub>3</sub> )	_____		ppm																																										
Oil or grease	_____		ppm																																										
Silica (SiO <sub>2</sub> )	_____		ppm																																										
Max water temperature	_____		°F																																										
Total suspended solids	_____		ppm																																										
Bacteria count	_____		cfu/ml																																										
(Other)																																													

**Marley / Class F400 Cooling Tower / Specifications: Base**

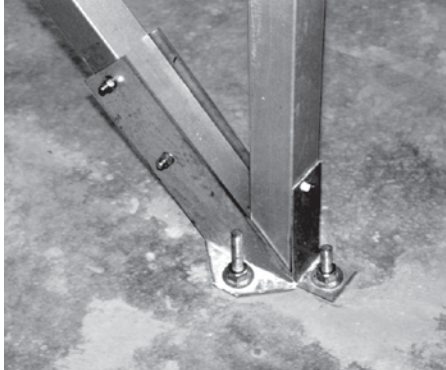
Specifications	Specification Value
<p><b>5.0 Structure:</b></p> <p><b>5.1</b> Tower framework shall consist of structural shapes of pultruded fiberglass composites having a flame spread rate of 25 or less. Columns and diagonals shall be 3" x 3" or larger box-section, with a minimum 1/4" wall thickness. Columns shall be spaced on no greater than 6'-0" centers transversely and 9'-0" centers longitudinally. Columns requiring anchorage shall be anchored to the concrete cold water basin by heavy gauge series 300 stainless steel anchor clips.</p> <p><b>5.2</b> Except at fill and fan deck support levels, longitudinal and transverse girts shall be 4" channel sections located on both sides of interior columns; and on the inside of all perimeter columns. Girts at the fill and fan deck support levels shall typically be 6" channel sections. These members sizes may vary depending on tower loading. Girt lines shall be located on vertical centers not to exceed 6'-4", except as may be required in towers requiring fill heights that would encounter the girt line. In that case, the lower girt line in the fill area may be lowered to provide room for the fill.</p> <p><b>5.3</b> A tension/compression system of diagonal braces shall stiffen the structure and transfer wind and seismic loads to the basin anchor points. Diagonal connectors used to transmit forces through column lines shall be of 1/2" thick fiber reinforced polyester (FRP). Diagonals shall be anchored to the cold water basin using heavy gauge series 300 stainless steel anchor clips. The line of action through the diagonal to the point of anchorage shall be straight.</p> <p><b>5.4</b> All structural connections and splices shall be through-bolted using full shank 1/2" diameter, or larger, series 300 stainless steel machine bolts, nuts and washers. Glued structural connections will not be allowed.</p> <p><b>5.5</b> Critical framing joints shall be augmented with 1/2" I.D., heavy wall (Sched. 40) structural sleeves of series 300 stainless steel or fiberglass pultrusion. Framing specific to those joints shall be factory-drilled to accept insertion of the sleeves. Bidders shall include with their quotation complete framework wind and/or seismic diagrams along with column operating and shutdown point loads for all models quoted, based upon the specified performance and design loadings.</p>	<p>■ Where the tower's incoming hot water temperature consistently exceeds 120°F, the strength characteristics of the pultruded fiberglass may be reduced, particularly in the distribution area of the tower. Depending upon the size of the tower, and the resultant safety margins, some changes in member sizes or resins used may be required.</p> <p>SPX Cooling Technologies has a number of <i>Marley Difference</i> publications having to do with both the science, and the art, of designing cooling towers and are available for download from our website. <i>Marley Difference</i> "Item S-7" of that series discusses diagonals, and explains the need to maintain a straight "line of action" throughout the diagonal.</p> <p>Series 300 stainless hardware is appropriate for the "normal" water conditions defined on page 5. If your air or water quality dictates hardware of higher premium (i.e. epoxy coating, type 316 stainless steel, silicon bronze, etc.), please see pages 13 through 15, and discuss your requirements with your Marley sales representative.</p> <p>The resin-rich surface veil applied to all molded or extruded FRP parts makes field-gluing inappropriate and structurally inadequate. Having no fiber content, this veil is the weakest area of the part, and must be properly removed to permit bonding to the fibrous structural layer. This is very difficult under field conditions and, coupled with the absence of any temperature and humidity control, makes field-glued joints not only ineffective, but potentially dangerous.</p> <p>To have structurally designed their offerings, bidders will have had to develop the framework wind and/or seismic. Please require them.</p>   

## Marley / Class F400 Cooling Tower / Specifications: Base

### Specifications

### Specification Value

#### 6.0 Fan Deck and Fan Cylinders:

6.1 The fan deck shall act as a working platform for maintenance personnel. It shall be pultruded fiberglass having a flame spread rating of 25 or less with a top surface at least 0.12" thick and shall have a slip resistant surface. Fan deck panels shall be supported by framing girts and shall interlock along the lengths of the panels to prevent differential deflections between panels. To minimize turbulence of airflow into the fan cylinder, fan deck protrusion into the fan cylinder opening shall not exceed 1".

6.2 Fan cylinders shall be molded FRP, no less than 7'-0" high, with eased inlets to promote smooth airflow at blade tips. The operating plane of the fan shall be at a level above the fan deck of at least 15% of the overall fan diameter. Fan tip clearance shall not exceed 0.5% of the fan diameter. If velocity recovery fan cylinders are used, they shall have a maximum flare angle of 12°, with a maximum assumed velocity recovery of 75% of the difference in average velocity pressure. Each fan cylinder segment shall be through-bolted to both the fan deck and a primary fan deck framing member. Fan cylinder connection and anchorage hardware shall be series 300 stainless steel.

■ FRP fan cylinders provide the close tip clearances and smooth airflow contour necessary for good fan performance. The inert, noncorroding nature of fiberglass assures that these characteristics will persist. *Marley Difference* "Item A-1a" explains the need for the specification language indicated at left.

If fire-retardant FRP is required or preferred for fan cylinders, please add the words "**having a flame spread rate of 25 or less**" after "FRP".



**Specifications**

**Specification Value**

**7.0 Fill and Drift Eliminators:**

**7.1** Fill shall be cellular film-type, thermoformed PVC, manufactured of 15 mil or heavier stock and shall be assembled into sturdy packs. For fill heights of 4'-0" or less, full height packs shall be required. For taller fill heights, no more than two vertical layers shall be allowed with the 4'-0" section on the bottom. Fill shall be supported as required to accommodate construction loads and operational loads and the specified 40 psf live load, as well as ice loads in freezing climates.

**7.2** Drift eliminators shall be thermoformed of 17 mil or heavier PVC. They shall be cellular type, triple-pass, and shall limit drift losses to no more than 0.005% of design GPM flow rate. They shall be factory-assembled into easily-handled packs that nest together to form a continuous plane of drift eliminators throughout the plan area of each tower cell. Eliminators shall be supported by framing girts on no greater than 6'-0" centers.

**8.0 Mechanical Equipment:**

**8.1** The primary air delivery system for each cell shall consist of an electric motor, an extended driveshaft, a geared speed-reduction unit, a multi-blade axial-type fan, and a rigid unitized support.

**8.2** Motors shall be \_\_\_\_-speed, single winding, variable torque, \_\_\_ hp maximum, TEFC, and specially insulated for cooling tower duty. Speed and electrical characteristics shall be \_\_\_ RPM, \_\_\_ Phase, \_\_\_ Hertz, \_\_\_ Volts. If the load applied to the motors exceeds 90% of their nameplate rating, then they shall have a 1.15 service factor and the service factor beyond 1.0 shall not be considered available for load.

**8.3** Motors shall be located outside the fan cylinders and shall be connected to the speed reducers by tubular, extended, full floating, non-lubricated driveshafts. Driveshaft tubes and flanges shall be manufactured of type 304 stainless steel. Couplings shall be hot dip galvanized cast iron, joined to the driveshaft by flexible neoprene bushings and type 316 stainless steel inserts. Connecting hardware shall be 300 stainless steel. Driveshaft assemblies shall be dynam-

■ In film-fill counterflow towers, great care is taken to assure full and even coverage of the fill with circulating water. Multiple layers of fill packs tend to defeat this effort by causing the water to redistribute itself after each layer. Minimizing the number of layers will assure minimal airflow disruption and when required, locating the one interface point nearer the spray chamber at the top of the fill section will reduce the tendency for fill fouling.

The water temperature limit of normal PVC film fill depends upon configuration. In order to optimize your fill material selection, please discuss your expected normal and excursion temperatures with your Marley sales representative.

Drift rate varies with design water loading, air rate, drift eliminator depth, and density. The indicated rate of 0.005% is easily achievable without premium cost. If a lower rate is required, please discuss with your Marley sales representative.

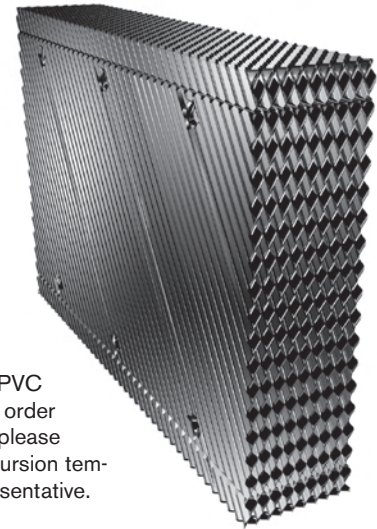

- • Typical speed choices are "single" or "two". Two-speed motors are worthy of your consideration because of the increased controllability they offer – and because of their significantly reduced annual power requirements.
- For 60 Hz power, single-speed design is 1800 RPM, and normal two-speed design is 1800/900 RPM.

Change the motor specifications to indicate the characteristics you require. Dual winding, explosion proof, 1800/1200 RPM, space heaters, etc.

- The driveshaft turns at the motor speed and is, therefore, most sensitive to operational imbalance. Stainless steel manufacture assures that the driveshaft will not become unbalanced as a result of corrosion.

See page 15 for optional all stainless steel, and carbon fiber driveshafts.



Specifications	Specification Value
<p>cally balanced at the factory at full motor speed. Two galvanized steel driveshaft guards anchored to the mechanical equipment support shall surround the driveshaft for containment in the event of failure.</p>	
<p><b>8.4</b> Gear reduction units shall be rightangle type, utilizing helical and/or spiral bevel matched gear sets. Cases shall be epoxy-coated, ASTM Class 20, gray cast iron. Bearings shall be tapered roller type. Gears and bearings shall be splash-lubricated in a bath of turbine type mineral oil, and units shall be capable of operating in either forward or reverse with equal facility. Speed reduction units using external oil pumps will not be allowed. Gear reducers shall meet or exceed the requirements of CTI STD-111 and AGMA Std. 420.04, and service factor at applied horsepower shall not be less than 2.0. They shall be run-in under load and adjusted at the factory, and the interior surfaces coated with a rust-proofing oil prior to shipment.</p>	<p>■ The Geareducer® is, essentially, the heart of your fan drive system. It must support the fan, rotate the fan at the appropriate speed, and maintain critical fan positioning within the fan cylinders—and must perform these functions reliably through many years of demanding use.</p> <p>Requiring adherence to the standards specified helps to assure that level of dependability.</p> <p>The extended oil line to an external gauge provides a means of checking the level of oil in the Geareducer. It also permits periodic oil changes at a convenient location.</p> 
<p><b>8.5</b> Each cell shall be equipped with an external oil level gauge and gear reducer drain line, located outside the fan cylinder near the motor.</p>	
<p><b>8.6</b> Fans shall have a minimum of six FRP or GRE (glass reinforced epoxy) blades, with appropriate twist and taper to produce maximum airflow. All blades shall be fabricated with consistent moment weights to permit the change-out of individual blades without the need for total fan rebalance. Hubs shall be fabricated of hot dip galvanized steel and ductile cast iron, assembled with series 300 stainless steel hardware. Spoke-type hubs, if used, shall be equipped with an FRP hub cover to prevent recirculation of air at the plane of the fan. Hubs shall be statically balanced at the factory.</p>	<p>■ Many of the large fans used on cooling towers operate at tip speeds approaching 13,000 ft/min. When the blade tips encounter the occasional solid droplet of water that escapes the eliminators, erosion of the leading edge can occur on fans whose designs do not address this problem. This has, over time, contributed to some fan failures in the past.</p> <p>Fans of the size used on large cooling towers are applied at speeds and horsepowers that generate considerable torque – and structural tubular steel resists this torque most effectively. The torque-tube design assures that all of the mechanical equipment remains aligned, and that the rotating fan is properly positioned within the fan cylinder. Hot dipping after fabrication assures that all steel surfaces will be heavily coated with zinc for long-term protection against corrosion.</p> 
<p><b>8.7</b> The complete mechanical equipment assembly for each cell shall be supported by a rigid, unitized, torque-tube type support that prevents misalignment between the motor and the gear reducer. Support shall be heavy-wall tubular steel, to which heavy plate platforms for the motor and gear reducer have been welded, as well as structural outriggers to provide structural stability and transmit loads into the tower structure. The assembly shall be hot dip galvanized after fabrication.</p>	

## Marley / Class F400 Cooling Tower / Specifications: Base

### Specifications

### Specification Value

#### 9.0 Casing:

9.1 The endwalls and sidewalls of the tower above the air inlet elevation, shall be cased with 8 oz/sq ft corrugated FRP panels attached to tower columns with stainless steel, self-tapping fasteners and self-sealing washers. Panels shall be lapped to shed water inward to the tower. Vertical joints shall be lapped and sealed watertight. Casing ends at tower corners shall be covered with 12 oz/sq ft FRP 90° corner rolls.

- If preferred, change casing weight from 8 oz/sq ft to either 10 oz/sq ft or 12 oz/sq ft.

Also, if fire-retardant casing is preferred, it would be appropriate to add the following sentence to the end of the paragraph at left: **“Casing panels and corner rolls shall have a flame spread rate of 25 or less.”**



#### 10.0 Hot Water Distribution System:

10.1 Hot water shall be distributed to the fill in each cell via a system of headers, laterals, branch arms, and nozzles, installed in the region above the fill and beneath the drift eliminators. Headers may be either RTR (reinforced thermosetting resin) or PVC. Laterals shall be PVC. Branch arms and nozzles shall be injection-molded polypropylene. The joint between branch arms and nozzles shall be threaded so nozzles can be easily removed for cleaning of the branch arms. Nozzles shall be of the large orifice, low-pressure, down-spray type, having no moving parts or restrictors that will promote clogging.

- This “side inlet” method of piping the cooling tower requires you to provide a header at the base of the tower, along with separate risers for each cell. Using this method, you may conveniently valve off cells on an individual basis.

In cold weather regions, you should also consider running a drain line from the riser to the cold water basin to drain the riser during shutdown in freezing weather. Bypasses, if used, should be designed only after thorough discussion with your Marley sales representative.

Water distribution in a cooling tower should be relatively equal throughout. Distribution systems which create uneven water distribution promote reduced tower performance by developing high water concentration areas which block air flow and/or low water concentration areas which create air bypass regions.

10.2 The piping system shall be sized for a flow velocity that will insure relatively equal flow to all areas of the cooling tower fill. Headers shall be equipped with individual 25 psi flanged inlets, drilled to conform to Class 125 and Class 150 ANSI requirements, located approximately 1'-0 outside the tower casing at or near the transverse centerline of each cell. Except for towers with 4'-0 plenums heights, headers shall be vented to atmosphere by an open standpipe at the downstream end of the header.

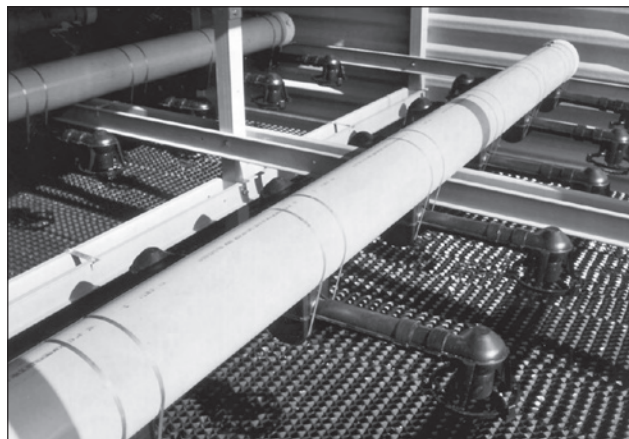

Specifications	Specification Value
<p><b>11.0 Cell Partitions:</b></p> <p><b>11.1</b> The tower shall be partitioned such that the fan of each cell can be operated and cycled independently of the remaining cells. Full-width, 8 oz/sq ft FRP panel partitions shall extend from casing to casing across the tower, and from the top of the fill upward to the underneath side of the fan deck floor.</p> <p><b>11.2</b> A full-length, 8 oz/sq ft FRP panel partition shall extend from endwall to endwall along the approximate centerline of the tower, rising from the normal operating water level to the underneath side of the fill. If endwalls are open for air entry, wind walls shall extend inward at an approximate 45° angle from the corner columns of the end cells to meet the longitudinal partition. The purpose of this partition system will be to prevent falling water from being blown out the leeward face of the tower.</p> <p><b>12.0 Access and Safety:</b></p> <p><b>12.1</b> The tower shall be designed and equipped to provide comfortable, safe access to all components requiring routine inspection and maintenance.</p> <p><b>12.2</b> The fan deck of the tower shall be surrounded by sturdy 4" x 4" pultruded FRP angle top rail and toeboard plus a 3.5" pultruded FRP channel intermediate rail, all conforming to OSHA standards. The guardrail shall be 42" high. The guardrail shall be 42" high. Top rails and intermediate rails shall be through-bolted to 3" x 3" columns both longitudinally and transversely. The toeboards shall be fastened to the tower columns or guardrail posts with self drilling/ self tapping screws.</p> <p><b>12.3</b> One endwall of the tower shall be equipped with a structural fiberglass stairway rising from the level of the cold water basin curb to the fan deck. Stairs shall be 30" wide with a slope of 41.5° and have an 8" rise and 9" run. Treads shall have a nonskid surface. Landings shall occur at 6'-0 elevations. Handrails and kneerails shall be 2" x 2", through-bolted to 3" x 3" stairway posts. All stairway bolts and fasteners shall be series 300 stainless steel. <span style="float: right;">▶▶▶▶▶</span></p>	<p>■ Multicell towers must have air plenum partitions between cells. Otherwise, air will be induced downward through an inoperative fan, bypassing the fill of the operating cell. Without these partitions, part-load or off-season operation of the tower would be completely unsatisfactory.</p> <p>Unless complete separation between cells is required for reasons of system operation, partitions in the fill area of film-fill counterflow towers serve no useful purpose. There is no tendency for distributed water to wander excessively beyond the limits of the tower cell.</p> <p>Without these wind walls, the area surrounding counterflow towers would quickly become unsightly—or in wintertime, potentially dangerous.</p> <p>■ The rigors of normal industrial cooling tower operation require that all vital areas of the tower be readily, easily, and safely accessed.</p> <p>Be extremely wary of those manufacturers who suggest that one of your access requirements is not really necessary. Their suggestion may be evidence that such access in their design is difficult—and may very well become a focus of significant cost to you in the future.</p> <p>■ Stairways are also available at both ends of the tower; and cased for snow and ice protection. In lieu of a stairway, you may only need or want an access ladder. See page 16.</p>

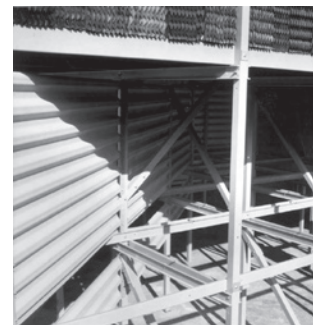

## Marley / Class F400 Cooling Tower / Specifications: Base

### Specifications

- 12.4** Each cell shall have a 36" square hinged access hatch in the fan deck floor, and a fiberglass ladder leading down to a landing at the drift eliminator level. A removal section through the eliminators lifts out for access into the spray chamber for nozzle cleaning and inspection.
- 12.5** Fan cylinders shall have removable segments for access to mechanical equipment components, and shall have a coupling guard, conforming to OSHA standards, to shroud that portion of the driveshaft that extends outside the fan cylinder.
- 13.0 Scope of Work:**
- 13.1** The cooling tower manufacturer shall be responsible for the design, fabrication, and delivery of materials to the project site, and for the erection of the cooling tower over a concrete basin and foundation. Cooling tower manufacturer will also supply anchor bolts. The concrete basin and foundation including stairway landing(s) shall have been designed and installed by others, based upon certified loads and dimensions provided by the cooling tower manufacturer. Unless otherwise specified, all external piping, headers, risers, valves, pumps, sumps and screens, controls, electrical wiring, fire protection, lightning protection, and water treatment equipment will be outside the cooling tower manufacturer's scope of work.

### Specification Value

- The access doors on other towers may be unreasonably small. Specifying the size of the door will cause those bidders to take exception, alerting you to a potential maintenance headache.

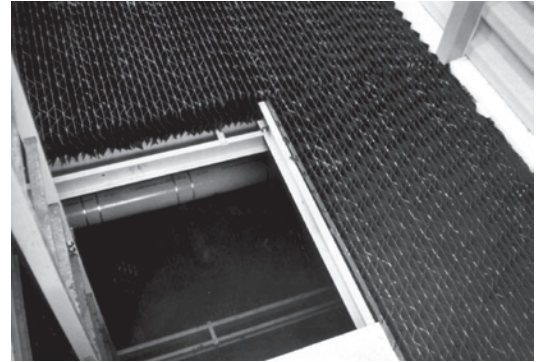

- Please be clear in your specifications and inquiry documents regarding the full scope of work expected. That will help assure that your bid comparisons will be made on as equal a basis as possible—and will help to avoid any misunderstandings during the execution and implementation of the contract.



Specifications	Specification Value
<p><b>Premium Hardware Options</b></p>	
<p><b>Level 1 - Epoxy-Coated Galvanized Steel</b></p>	
<p><u>8.3</u> <i>Change the last sentence to read:</i> Two triple-epoxy-coated, galvanized steel driveshaft guards anchored to the mechanical equipment support shall surround the driveshaft for containment in the event of failure.</p>	<p>■ All of the material changes listed under Level 1 are recommended where chlorides are below 1500 ppm (as sodium chloride) or below 910 ppm (as chloride) but acidity is less than pH 6.5 –or in the presence of sulfides.</p> <p>The materials of construction indicated in the base specification are entirely suitable for the "normal" water conditions defined on page 5. If your water quality is typified by the conditions indicated in the description above, all of the changes indicated on this page may be required. However, many of the components mentioned are outside contact with the circulating water stream and, therefore, may not require specification revision. Bolts, nuts and washers, of course, are Series 300 stainless steel as standard.</p> <p>Also, several other water chemistries can occur that may or may not necessitate changes in materials of construction and/or operating procedures. Prior to finalizing the tower selection and specification, we ask that you provide us with your best analysis of what your circulating water quality and chemistry will be.</p> <p>The value of the specification revision is, of course, that they help assure you will have achieved maximum longevity from your cooling tower in its anticipated operating environment.</p>
<p><u>8.6</u> <i>Add the following sentence at the end of this paragraph:</i> Galvanized steel components shall be epoxy-coated after galvanizing to a dry film thickness of 12 mils.</p>	
<p><u>8.7</u> <i>Change the last sentence to read:</i> The assembly shall be hot dip galvanized after fabrication, and epoxy-coated after galvanizing to a dry film thickness of 12 mils.</p>	
<p><b>Level 2 - Type 316 Stainless Steel</b></p>	
<p><u>5.1</u> <i>Change the last sentence to read:</i> Columns requiring anchorage shall be anchored to the concrete cold water basin by heavy gauge type 316 stainless steel anchor clips.</p>	<p>■ All of the material changes listed under Level 2 are recommended where chlorides are between 1500 ppm and 4000 ppm (as sodium chloride) or between 910 ppm and 2425 ppm (as chloride).</p> <p>The materials of construction indicated in the base specification are entirely suitable for the "normal" water conditions defined on page 5. If your water quality is typified by the conditions indicated in the description above, all of the changes indicated on this page may be required. However, many of the components mentioned are outside contact with the circulating water stream and, therefore, may not require specification revision.</p> <p>Also, several other water chemistries can occur that may or may not necessitate changes in materials of construction and/or operating procedures. Prior to finalizing the tower selection and specification, we ask that you provide us with your best analysis of what your circulating water quality and chemistry will be.</p> <p>The value of the specification revision is, of course, that they help assure you will have achieved maximum longevity from your cooling tower in its anticipated operating environment.</p>
<p><u>5.3</u> <i>Change the third sentence to read:</i> Diagonals shall be anchored to the cold water basin using heavy gauge type 316 stainless steel anchor clips.</p>	
<p><u>5.4</u> <i>Change the first sentence to read:</i> All structural connections and splices shall be through-bolted using full shank 1/2" diameter, or larger, type 316 stainless steel machine bolts, nuts and washers.</p>	
<p><u>6.2</u> <i>Change the last sentence to read:</i> Fan cylinder connection and anchorage hardware shall be type 316 stainless steel.</p>	
<p><u>8.3</u> <i>For a stainless steel driveshaft change the second, third and fourth sentences to read:</i> Driveshaft tubes and flanges shall be manufactured of type 304 stainless steel. Couplings shall be cast 316 stainless steel, joined to the driveshaft by flexible neoprene bushings and type 316 stainless steel inserts.</p>	



Specifications	Specification Value
<p><i>Also, the last sentence to read:</i> Two triple-epoxy-coated, galvanized steel driveshaft guards anchored to the mechanical equipment support shall surround the driveshaft for containment in the event of failure.</p> <p><i>For a carbon fiber driveshaft with 316 stainless steel couplings, replace entire paragraph 8.3 with the description found on pages 15 and 16.</i></p> <p><b>8.6</b> <i>Add the following sentence at the end of this paragraph:</i> Galvanized steel components shall be epoxy-coated after galvanizing to a dry film thickness of 12 mils (.012").</p> <p><b>8.7</b> <i>Change the last sentence to read:</i> The assembly shall be hot dip galvanized after fabrication, and epoxy-coated after galvanizing to a dry film thickness of 12 mils (.012").</p> <p><b>Level 3 - Silicone Bronze</b></p> <p><b>5.1</b> <i>Change the last sentence to read:</i> Columns requiring anchorage shall be anchored to the concrete cold water basin by heavy gauge silicon bronze anchor clips.</p> <p><b>5.3</b> <i>Change the third sentence to read:</i> Diagonals shall be anchored to the cold water basin by heavy gauge silicon bronze anchor clips.</p> <p><b>5.4</b> <i>Replace the first sentence with the following:</i> All structural connections and splices shall be through-bolted using full shank 1/2" diameter, or larger, silicon bronze machine bolts, nuts and washers. Exposed bolt heads, threads and nuts shall be covered with plastic cups to prevent water impact erosion.</p> <p><b>6.2</b> <i>Change the last sentence to read:</i> Fan cylinder connection and anchorage hardware shall be series 300 stainless steel or type 316 stainless steel.</p> <p><b>8.3</b> <i>For an all stainless steel driveshaft change the second, third and fourth sentences to read:</i> Driveshaft tubes and flanges shall be manufactured of type 304 stainless steel. Couplings shall be cast 316 stainless steel, joined to the driveshaft by flexible neoprene bushings and type 316 stainless steel inserts. Connecting hardware shall be 316 stainless steel.</p>	<p>■ <b>All of the material changes listed under Level 3 are recommended where chlorides are above 4000 ppm (as sodium chloride) or above 2425 ppm (as chloride) and where neither sulfides or ammonia are present.</b></p> <p>The materials of construction indicated in the base specification are entirely suitable for the "normal" water conditions defined on page 5. If your water quality is typified by the conditions indicated in the description above, all of the changes indicated on this page may be required. However, many of the components mentioned are outside contact with the circulating water stream and, therefore, may not require specification revision.</p> <p>Also, several other water chemistries can occur that may or may not necessitate changes in materials of construction and/or operating procedures. Prior to finalizing the tower selection and specification, we ask that you provide us with your best analysis of what your circulating water quality and chemistry will be.</p> <p>The value of the specification revision is, of course, that they help assure you will have achieved maximum longevity from your cooling tower in its anticipated operating environment.</p> <p><b>Silicon bronze, while very resistant to corrosion in a chloride environment, is subject to erosion in high-flow areas. Therefore, plastic cups, designed for this service, are used to prevent direct water impingement on the hardware.</b></p>

Specifications	Specification Value
<p><i>Also, change the last sentence to read:</i> The driveshaft guards shall be epoxy coated after galvanizing to a dry film thickness of 12 mils (.012").</p> <p><i>For a carbon fiber driveshaft with 316 stainless steel couplings, replace the entire paragraph 8.3 with the description found on pages 15 and 16.</i></p> <p><b>8.6</b> <i>Add the following sentence at the end of the paragraph:</i> Galvanized steel components shall be epoxy coated after galvanizing to a dry film thickness of 12 mils (.012").</p> <p><b>8.7</b> <i>Change the last sentence to read:</i> The assembly shall be hot-dip galvanized after fabrication, and epoxy-coated after galvanizing to a dry film thickness of 12 mils (.012")</p> <p><b>Driveshaft Material Options</b></p> <p><b>All Stainless Steel Driveshaft:</b></p> <p><b>8.3</b> <i>Replace the second, third and fourth sentences with the following:</i> Driveshaft tubes and flanges shall be manufactured of type 304 stainless steel. Couplings shall be cast 316 stainless, joined to the driveshaft by flexible neoprene bushings and type 316 stainless steel inserts. Connecting hardware shall be 300 series stainless steel.</p> <p><b>Carbon Fiber Driveshaft / Stainless Steel Couplings:</b></p> <p><b>8.3</b> <i>Replace the third paragraph with the following:</i> Motors shall be located outside the fan cylinders and shall be connected to the speed reducers by tubular, extended, full floating, non-lubricated driveshafts. Driveshaft tubes shall be carbon fiber/glass/epoxy composite. Flanges shall be manufactured of type 316 stainless steel, attached to the tube by type 316 stainless steel compression rings. Couplings shall be cast 316 stainless, joined to the driveshaft by flexible neoprene bushings and type 316 stainless steel inserts. Connecting hardware shall be 316 stainless steel. Driveshaft assemblies shall be dynamically balanced at the factory at full motor speed. Two triple-epoxy-coated, galvanized steel driveshaft guards anchored to the mechanical equipment support shall surround the driveshaft for containment in the event of failure.</p>	<p>■ Use where chloride levels in the circulating water and drift may exceed 750 ppm, as sodium chloride.</p> <p>■ Carbon fiber driveshafts are preferred by many customers on the strength of their ability to remain dimensionally unaffected by long stationary periods in direct sunlight. Steel driveshafts may go through temporary unbalance in those circumstances.</p>

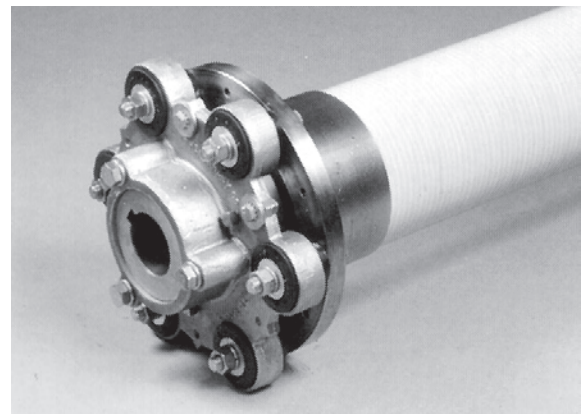

## Marley / Class F400 Cooling Tower / Specifications: Options

Specifications	Specification Value
<b>Access and Maintenance Options</b>	
<b>Vertical Ladder at End of Tower:</b>	
<b>Fiberglass Ladder:</b>	
<p><u>12.3</u> <i>Add the following sentences to this paragraph:</i> A fiberglass ladder and safety cage designed per OSHA recommendations shall be provided at the other end of the tower. Ladder shall rise from the level of the cold water basin curb to the fan deck.</p>	<ul style="list-style-type: none"> <li>■ These are sometimes referred to as “escape” ladders. They are a ready means of egress in case of emergency. If you want this ladder on your tower, please make the change indicated at left.</li> </ul>
<b>Steel Ladder:</b>	
<p><u>12.3</u> <i>Add the following sentences to this paragraph:</i> A hot dip galvanized vertical steel ladder with safety cage per OSHA recommendations shall be provided at the other end of the tower. Ladder shall rise from the level of the cold water basin curb to the fan deck.</p>	<ul style="list-style-type: none"> <li>■ On long towers, a second stairway is a very desirable option for your maintenance people.</li> </ul>
<b>Second Stairway at End of Tower:</b>	
<p><u>12.3</u> <i>Change the first sentence to read as follows:</i> Both endwalls of the tower shall be equipped with structural fiberglass stairways rising from the level of the cold water basin curb to the fan deck.</p>	<ul style="list-style-type: none"> <li>■ As the specification wording implies, the enclosed stairway is of great benefit in those geographic regions where heavy snowfalls are the norm.</li> </ul>
<b>Enclosed Stairway:</b>	
<p><u>12.3</u> <i>Change this paragraph to read:</i> The stairway shall be enclosed with tower casing material to keep out snow and sleet. Roof support headroom shall be 7'-0" above top stairway landing. Latched doors shall be provided at the entrance and exit of the stairway. The door at the fan deck elevation shall open inward to prevent snow and ice buildup from rendering the door inoperable. Stairway side casings shall be translucent for visibility.</p>	



**Marley / Class F400 Cooling Tower / Specifications: Options**

Specifications	Specification Value
<p><b>Mechanical Equipment Temporary Access Catwalk:</b></p> <p><u>12.5</u> <i>Add the following sentence to this paragraph: Provide a 24" wide portable expanded aluminum catwalk, complete with guardrail, that will extend from the fan cylinder access-way to the fan hub/gear reducer/driveshaft region.</i></p> <p><b>Mechanical Equipment Permanent Access System:</b></p> <p><u>12.5</u> <i>Add the following to this paragraph: Each cell shall be equipped with a 24" wide, permanently installed walkway extending from the fan cylinder access-way to a work platform at the fan hub / gear reducer / driveshaft region. Catwalk and work platform shall be FRP, and shall be equipped with FRP guardrails.</i></p> <p><b>Endwall Davit:</b></p> <p><u>12.5</u> <i>Add the following after this paragraph: A permanent 1000 lb capacity galvanized steel davit shall be provided at the end of the fan deck to facilitate movement of equipment between the fan deck level and grade. Hoist, rigging, and cables will be provided by the owner.</i></p>	<ul style="list-style-type: none"> <li>■ This catwalk spans girt lines and provides short-term access to the mechanical equipment. It precludes the need to provide temporary planking.</li>   <li>■ Normally, the fan deck level at the end of the tower is readily accessible by a small crane or "cherry picker", making the derrick unnecessary.</li> </ul>

**Specifications**

**Specification Value**

**Miscellaneous Options**

**Fan Cylinder View Port:**

6.2 Add the following to this paragraph: Each fan cylinder shall include a 6" diameter, screened view port with a removable clear plastic window.

■ Allows online viewing of fan operation.

**Vibration Limit Switch:**

8.8 Add the following paragraph in the *Mechanical Equipment section*: A single-pole, double-throw vibration limit switch in a NEMA 4 housing shall be installed on the mechanical equipment support for wiring into the owner's control panel. The purpose of this switch will be to interrupt power to the motor in the event of excessive vibration. It shall be adjustable for sensitivity, and shall require manual reset.

■ Unless specified otherwise, a Marley M-5 vibration switch will be provided. The requirement for manual reset assures that the tower will be visited to determine the cause of excess vibration.



**Low Oil Switch:**

8.8 Add the following paragraphs in the *Mechanical Equipment section*: A solid state, capacitance-actuated, CSA approved low oil level switch shall be provided and installed outside the fan cylinder for wiring into the owner's control panel.

■ Unless specified otherwise, a Robertshaw Level-Tek Model 318A will be provided. This can be wired into a control or monitoring system.

## Marley / Class F400 Cooling Tower / Options

---

Space does not permit definition and explanation of all of the possible options that can be applied to the Class F400 cooling tower. Please refer to the list below for options not covered in this publication and contact your SPX Cooling Technologies sales representative for additional information.

- Deep cold water basin
- Splash fill
- Hudson fan
- Full height partitions
- Fire protection sprinkler system
- Second layer of eliminators
- Variable frequency drives
- Hansen speed reducer
- Addax drive shaft
- Special design loads
- Severe duty
- Steel cold water basin
- Fit existing cold water basin
- Special inlet piping
- Custom stretch frame
- Clog resistant film fills
- Polypropylene high temp film fills
- Back-to-back cells
- Louvers
- Cofimco fan
- Fire-resistant fiberglass
- Lightning protection system
- Resin sealing of drilled holes and cuts
- Air inlet screens
- Architectural casing
- Structural design calculations
- Fiber reinforced cement board fire-wall
- Closed endwalls or sidewalls
- Fiberglass cold water basin
- Concrete basin design
- Vinyl ester resin
- Cantilever design
- SafPlank Fan Deck