

Thermo Scientific Sarasota FD910 Sarasota FD950 Sarasota FD960

Liquid Density Meters for
General Industrial, Chemical
and Fiscal Applications

Thermo Scientific Sarasota liquid density meters accurately measure density or density related variables. These online continuous meters provide key information for process monitoring and control, quality control, product interface detection, and custody transfer applications to minimize product waste and reduce costs.



Features

- Continuous, online density monitoring
- Measurement at process conditions
- Straight through flow path
- Materials to suit applications
- Compact and lightweight, easy to install
- Hazardous area approvals
- Converter electronics to suit application



Applications

- Blending
- Product identification
- Interface detection
- Dilution measurement
- Process/quality control
- SG measurement
- Process efficiency
- Waste minimization
- Product consistency
- Volumetric to mass flow metering systems



Repeatable & Accurate

Thermo Scientific Sarasota liquid density meters fulfill demanding application requirements within the oil and gas, petrochemical, and chemical industries. These devices utilize the proven vibrating element design which is widely accepted as the most accurate method of continuous, online density measurement. In fact, our twin tube design is inherently more stable than single tube technology, and an integral, high grade PT100 temperature element within the instrument allows compensation of the density meter for temperature effect and may be used for compensation to reference conditions. Our meters detect any variation of process constituents or final product quality in near real-time to improve productivity, minimize product waste and reduce costs when compared to sampling methods.

Compact & Easy-to-Install

Compact and lightweight, the density meters tolerate significant plant vibration and can be installed directly into existing pipe work without the need for upstream flow conditioning or instrument supports. Installation is quick and simple with minimal pipeline disturbance or process downtime. The straight-through sensor offers an unobstructed flow path to ensure minimal pressure drop and higher flow rates to keep your products moving at optimal speed.

Durable & Functional

A choice of sensor materials is offered for wetted parts, including Hastelloy® C276 for improved corrosion resistance, Ni-Span C® for its low temperature coefficient for fiscal applications, and stainless steel for general industrial use. With hazardous area approvals and secondary containment on all models, these dependable instruments withstand tough industrial environments to ensure a significant return on investment.

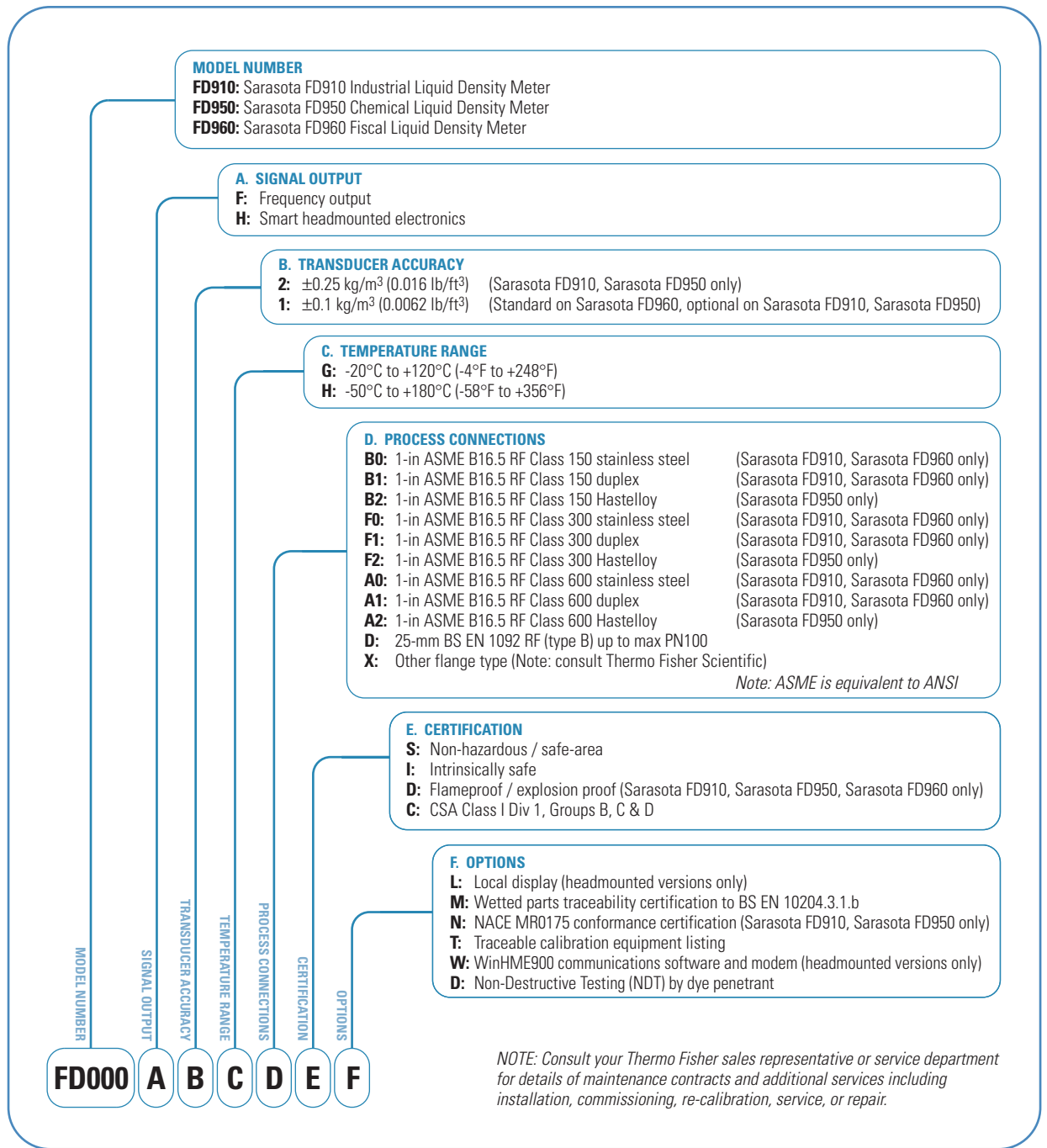

The Sarasota FD910 for Industrial Applications

The Sarasota FD910 meets the demands of general process monitoring and control applications across a vast number of industries. With its stainless steel construction, the Sarasota FD910 industrial density meter is best suited to those general process applications that do not require the specialist materials offered by the other models in the range.

The Sarasota FD950 for Chemical Applications

The wetted parts of the Sarasota FD950 are made of Hastelloy C276 making it the most corrosion resistant option of the range. It is ideal for aggressive applications in the petrochemical, chemical and pharmaceutical industries.

The Sarasota FD960 for Fiscal/Custody Transfer Applications

High-value liquid hydrocarbons must be identified and measured accurately and quickly to minimize product waste and determine custody transfer responsibilities. The superior performance of the Sarasota FD960 fiscal density meter makes it the right choice for custody transfer as well as multi-product pipeline metering and interface detection systems. The low temperature coefficient of Ni-Span C wetted parts allows the Sarasota FD960 to offer superior accuracy with minimal pressure drop. Typical applications include product blending, batch control, dilution measurement, product identification, interface detection and tanker loading.



Calibration and Service

Calibration of Thermo Scientific liquid density meters is conducted in-house on a calibration rig that is traceable to national standards. Supporting documentation is available including a traceable equipment list. For most applications, installation is straightforward, on-site calibration is generally unnecessary and the instruments are usually maintenance-free. However, our dedicated service team offers installation, commissioning, maintenance and repair service for our liquid density meters and associated electronics. On-site visits, in-house repairs and maintenance contracts can be arranged as required.

Sarasota FD910 / Sarasota FD950 / Sarasota FD960 Dimensional Diagram

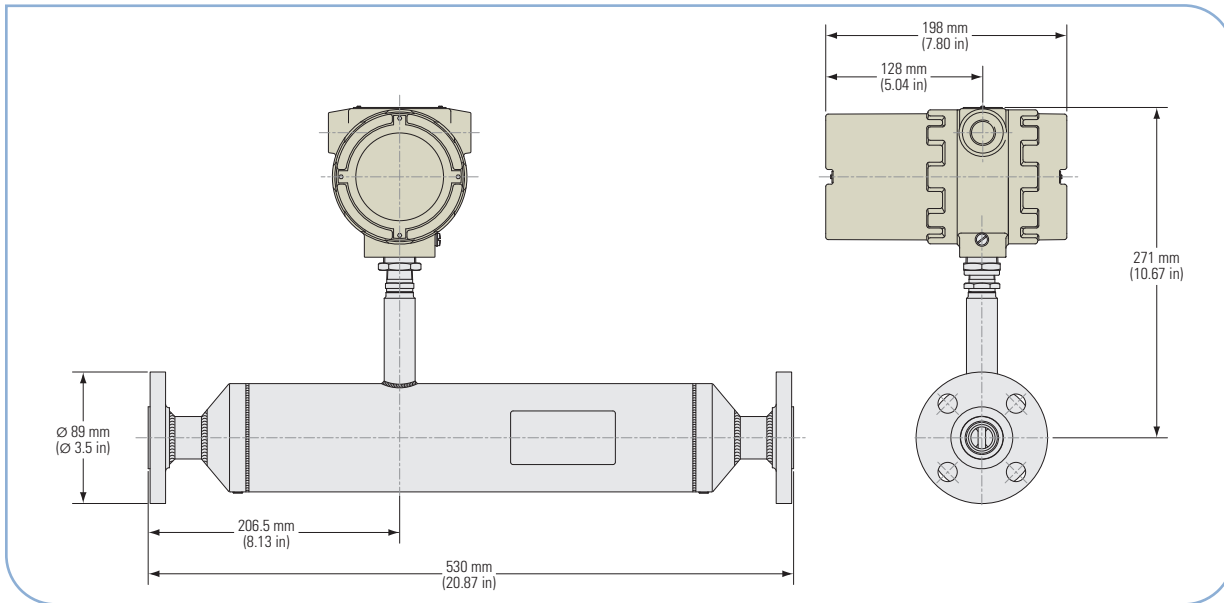

Thermo Scientific Sarasota HME900



Thermo Scientific Sarasota CM515

Density Converter Electronics

Thermo Scientific Sarasota liquid density meters can provide output variables, such as specific gravity, % concentration, °Brix, °API, °Baume, line density or referred density, when used in conjunction with a Sarasota density converter. The Thermo Scientific Sarasota HME900 field mounted density converter option provides a direct HART® compatible 4-20 mA output, whereas the Sarasota CM515 panel-mounted computer provides a local display and a variety of operator selectable outputs that feed into a plant's optimization system. Contact us today to learn how our range of products will help you reduce waste as well as improve your process and your bottom line.

Thermo Scientific Sarasota Liquid Density Meters

Functional Specifications

| | |
|---------------------------------|--|
| Transducer Calibration Accuracy | Available to ± 0.1 kg/m ³ (± 0.0062 lb/ft ³) |
| Repeatability | 0.02 kg/m ³ (0.0012 lb/ft ³) |
| Flow Range | Vertical installation: 0 l/min to 300 l/min (0 USG/min to 79 USG/min); Horizontal installation: 5 l/min to 300 l/min (1.3 USG/min to 79 USG/min) |
| Operating Density Range | 0 kg/m ³ to 2100 kg/m ³ (0 lb/ft ³ to 131.1 lb/ft ³) |
| Installation | Vertical installation (standard), horizontal installation (optional); No instrument or pipework supports required |
| Pressure Effect (corrected) | 0.003 kg/m ³ /bar (0.00013 lb/ft ³ /psi) note: correction coefficients applied |
| Temperature Effect (corrected) | 0.005 kg/m ³ /°C (0.0002 lb/ft ³ /°F) note: correction coefficients applied |
| Density Meter Dimensions | See dimensional diagrams |
| Shipping Dimensions | 590 mm x 390 mm x 290 mm (approx 24 in x 16 in x 12 in) |
| Net Weight | 11 kg (24 lb) |
| Shipping Weight | 15 kg (33 lb) |
| Environmental Rating | IP65 (NEMA 4X) |
| Electrical Connections | Screw terminals; Cable entry: 2 x 3/4-in NPT |
| Temperature Measurement | High accuracy 1/2 DIN integral 4-wire PT100 |
| Local Display (H option) | 4 1/2-digit 7.6 mm (0.3 in) 7-segment LCD display. Resolution 0.1% or 0.01% depending on display variable. |
| Secondary Containment | As flange rating to Class 300 then 2.5 times maximum safety flange rating to Class 600 |
| Factory Calibration Range | 650 kg/m ³ to 1600 kg/m ³ (40.58 lb/ft ³ to 99.98 lb/ft ³) |
| Ambient Temperature Range | -20°C to +60°C (-4°F to +140°F) ambient |
| Process Temperature Range | Sarasota FD910 / FD950 / FD960: -50°C to +180°C (-58°F to +356°F) |
| Output | F option (frequency output): Frequency related to density on 2-wire current modulated loop 6 mA to 18 mA; 4-wire PT100 H option (headmounted electronics): Analog 4-20 mA related to density or density derived variable; HART protocol |
| Power Supply | F option (frequency output): 13-28 VDC 10 mA average (peak 18 mA) H option (headmounted electronics): 2 x 13-28 VDC 25 mA; 4-20 mA current pressure input available |
| Maximum Operating Pressure | Sarasota FD910 / FD950 / FD960: as flange rating |

Material Specifications

| | |
|---------------------|---|
| Sensor | Sarasota FD910 stainless steel (316L / 1.4404); Sarasota FD950: Hastelloy C276; Sarasota FD960: Ni-Span C |
| Other Wetted Parts | Sarasota FD910 (Class 150, 300) / FD960: 316L stainless steel (316L / 1.4404) Sarasota FD910 (Class 600) / FD950: Hastelloy C276 |
| Case | Stainless steel (316L / 1.4404) |
| Electronics Housing | Copper free aluminum grey epoxy finish; Plate glass window for local display option |

Process Connections

| | |
|--|---|
| 1-in ASME B16.5 RF (raised face) | Sarasota FD910 / FD960: stainless steel (316L / 1.4404) – Class 150, 300 or 600 Sarasota FD910 / FD960: duplex (A 182 Gr.F51) – Class 150, 300 or 600 Sarasota FD950 only: Hastelloy C276 – Class 150, 300 or 600 |
| 25-mm BSEN1092 RF (raised face - type B) | Sarasota FD910 / FD950 / FD960: Up to maximum PN100 |
| Other Flange Types | Consult Thermo Fisher |

Compliance/Certification

| | |
|--|---|
| Quality Assurance | ISO 9001:2000 |
| CE mark | Compliant |
| Electromagnetic Compatibility | Compliant (EN 61326:1997) |
| Pressure Equipment Directive (97/23/EC) | Sarasota FD910 / FD950 / FD960: category III |
| Low Voltage Directive | Compliant |
| Safe Area Use | As standard |
| BS EN ISO 15156 / NACE MR0175 | |
| Conformance | Available on Sarasota FD910 and Sarasota FD950 only |
| ATEX Conformance: Intrinsically Safe (94/9/EC) | F option (frequency output): Ex II 1 G EEx ia IIC T6 (-20°C ≤ Ta ≤ +60°C) H option (headmounted electronics): Ex II 1 G EEx ia IIC T4 (-20°C ≤ Ta ≤ +60°C) |
| ATEX Conformance: Flameproof (94/9/EC) | Sarasota FD910 / FD950 / FD960 only: Ex II 2 G EEx d IIC T4 (Tamb = -20°C to +60°C) or T3 (Tamb = -20°C to +60°C) Temperature classification of T4 or T3 for use with maximum process fluid temperature of +115°C or +180°C respectively |
| Canadian Standards Association (CSA) | Sarasota FD910 / FD950 / FD960 only: Explosion-proof Class 1, Groups B, C and D |
| Calibration Certification | Calibration traceable to national standards. Calibration certificates supplied as standard. Optional traceable calibration equipment listing available |
| Material Traceability | Wetted parts traceability to BS EN 10204.3.1.b; Certification available |

© 2008 Thermo Fisher Scientific Inc. All rights reserved. HART is a registered trademark of the HART Communication Foundation. Tri-Clamp is a registered trademark of Tri-Clover, Inc. Hastelloy is a registered trademark of Haynes International, Inc. Ni-Span C is a registered trademark of the Special Metals Corporation. All other trademarks are the property of Thermo Fisher Scientific Inc. and its subsidiaries. Results may vary under different operating conditions. Specifications, terms and pricing are subject to change. Not all products are available in all countries. Please consult your local sales representatives for details. Literature Code PI.2024.1108

| | |
|--|---|
| Unit 702-715, 7/F Tower West Yonghe Plaza No. 28, Andingmen East Street Beijing 100007 CHINA | +86 (10) 8419-3588 +86 (10) 8419-3580 fax |
| A-101, ICC Trade Tower, Senapati Bapat Road Pune 411016 Maharashtra INDIA | +91 (20) 6626 7000 +91 (20) 6626 7001 fax |
| Ion Path, Road Three, Winsford, Cheshire CW7 3GA UK | +44 (0) 1606 548700 +44 (0) 1606 548711 fax |
| 1410 Gillingham Lane Sugar Land, TX 77478 USA | +1 (800) 437-7979 +1 (713) 272-0404 +1 (713) 272-4573 fax |